

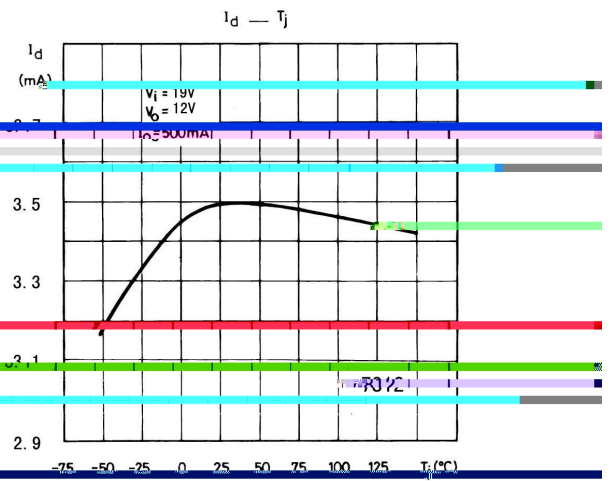

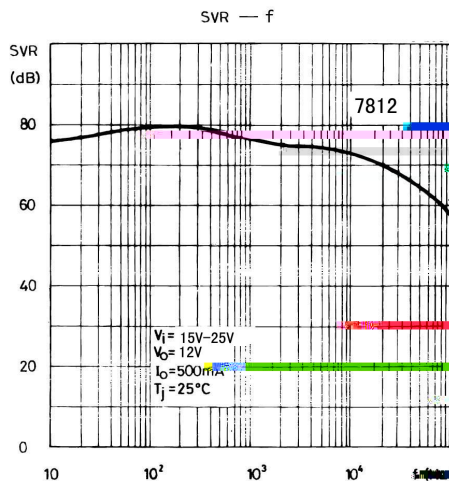

/ Electrical Characteristic Curve

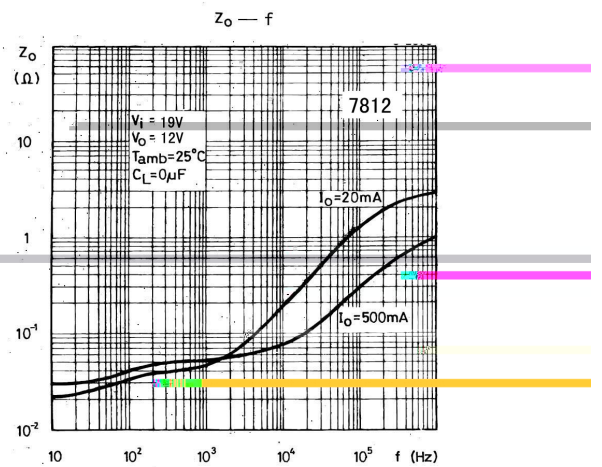

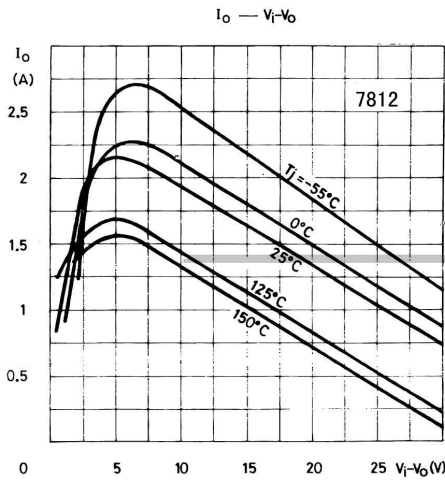
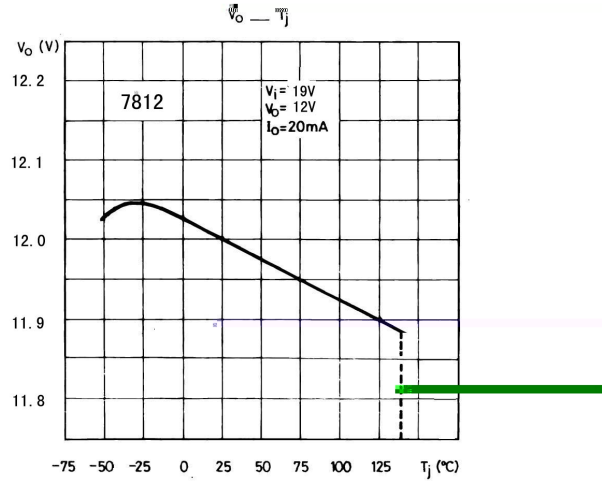
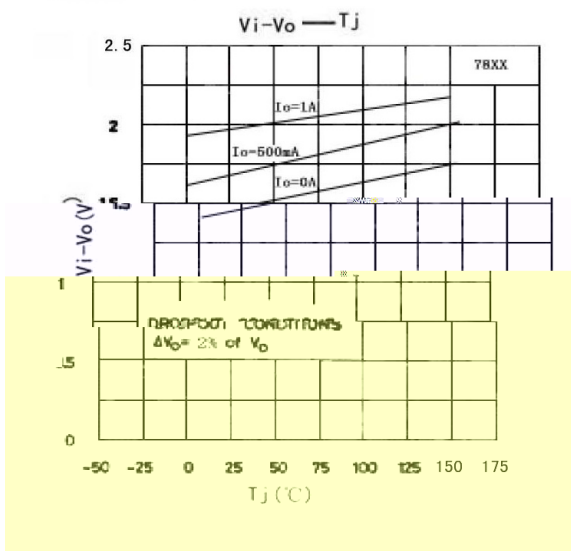

/ Marking Instructions

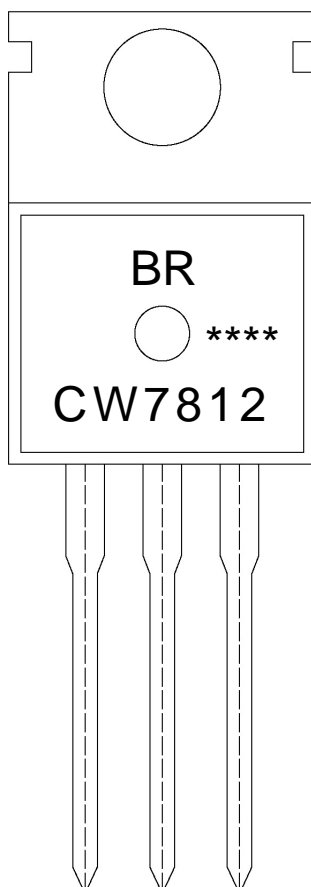

BR

CW7812

\*\*\*\*

Note:

BR: Company Code

CW7812: Product Type Code

\*\*\*\*: Lot No. Code, code change with Lot No

**( ) / Temperature Profile for Dip Soldering(Pb-Free)**

Note:

- |   |        |            |  |
|---|--------|------------|--|
| 1 | 25 150 | 60 90sec;  | 1.Preheating:25~150 , Time:60~90sec.     |
| 2 | 255±5  | 5±0.5sec;  | 2.Peak Temp.:255±5 , Duration:5± 0.5sec. |
| 3 |        | 2 10 /sec. | 3. Cooling Speed: 2~10 /sec.             |

**/ Resistance to Soldering Heat Test Conditions**

270±5                      10± 1 sec.                      Temp.:270±5                      Time:10±1 sec

**/ Packaging SPEC.**

/ BULK

Package Type	Units					Dimension (unit mm <sup>3</sup> )		
	Units/Bag /	Bags/Inner Box /	Units/Inner Box /	Inner Boxes/Outer Box /	Units/Outer Box /	Bag	Inner Box	Outer Box
TO-220/F	200	10	2,000	5	10,000	135×19.05×6.35	125×42.4(2374.3(9).4(0)-6.3(	)16