

/ Descriptions

/ Features

/ Applications

DC/DC

/ Equivalent Circuit

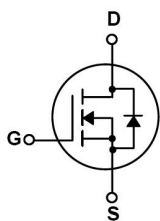

/ Pinning

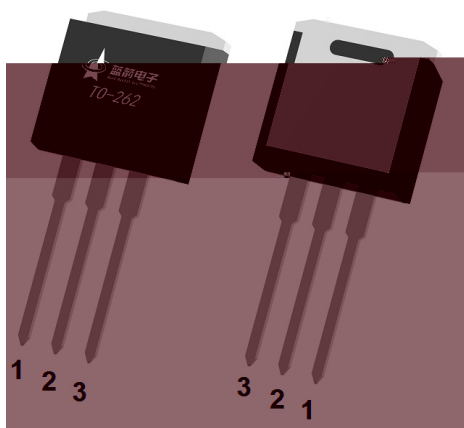

/ Marking

			μ			

/ Electrical Characteristic Curve

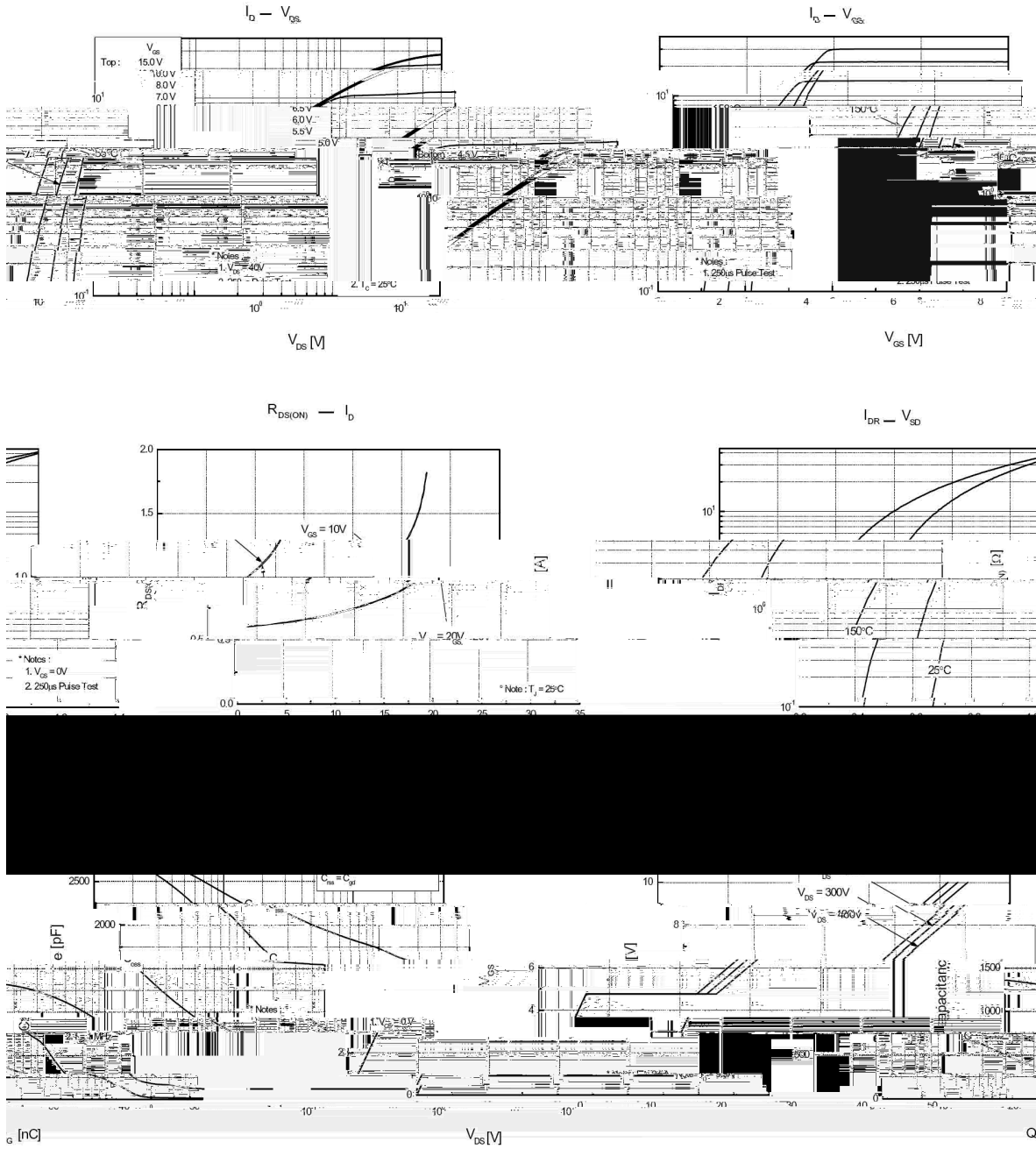

/ Package Dimensions

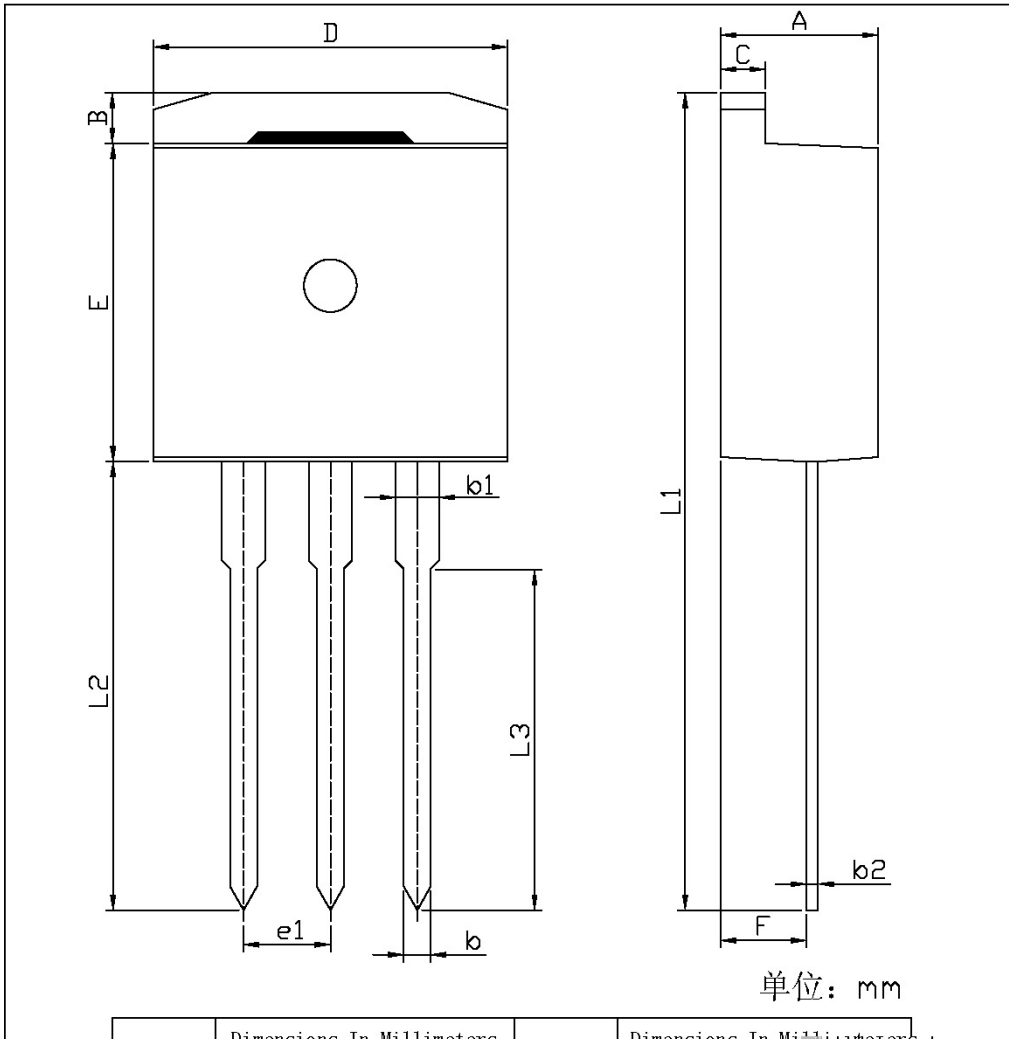

单位: mm

Symbol	Dimensions..In..Millimeters..		Symbol	Dimensions..In..Millimeters	
	Min	Max		Min	Max
A	4.30	4.70	E	9.00	9.40
B	1.00	1.40	e1	2.34	2.74
b	0.70	0.90	F	2.20	2.60
b1	1.27		L1	22.60	23.60
b2	0.40	0.60	L2	12.60	13.60
C	1.20	1.40	L3	9.60	10.60
D	9.80	10.20			

T0-262

/ Marking Instructions

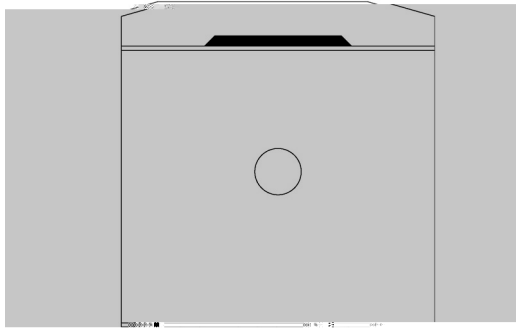

BR

() / Temperature Profile for Dip Soldering(Pb-Free)

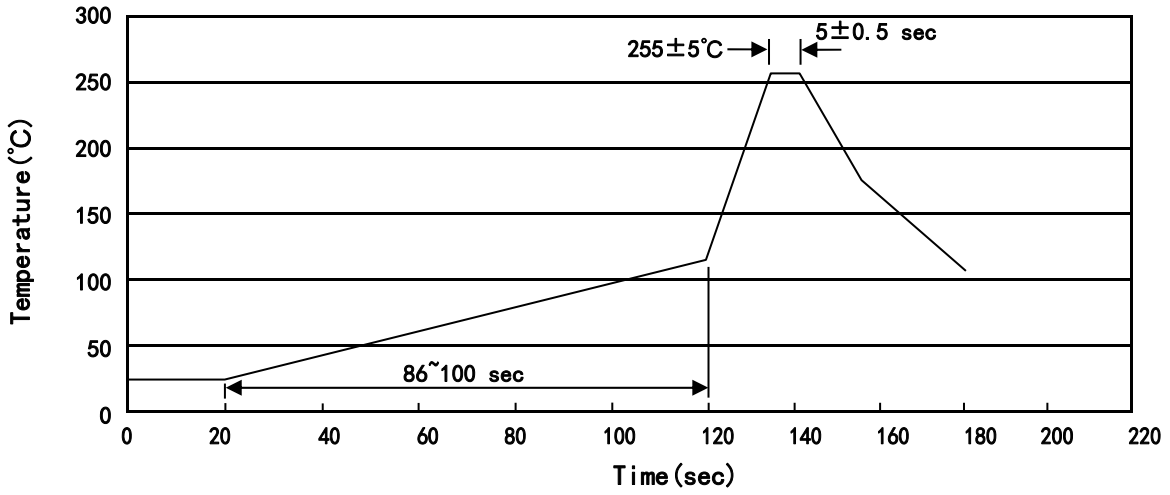

± ± ± ±

/ Resistance to Soldering Heat Test Conditions

± ±

/ Packaging SPEC.

	Units/Tube	Tubes/Inner Box	Units/Inner Box	Inner Boxes/Outer Box	Units/Outer Box	Tube	Inner Box	Outer Box
	/	/	/	/	/			

/ Notices