

A	2019.4.17				
B	2020-5-12	1/3/4	RDSON 60mR 50mR		
C	2020-7-23	11			
D	2020/11/4	1 2			

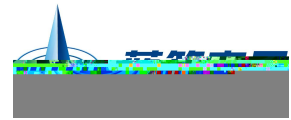

BRCL3130ZF is a high integration solution for lithium-ion/polymer battery protection. BRCL3130ZF contains advanced power MOSFET, high-accuracy voltage detection circuits and delay circuits.

BRCL3130ZF is put into an ultra-small DFN2' 2-6L package and only one external component makes it an ideal solution in limited space of battery pack. BRCL3130ZF has all the protection functions required in the battery application including overcharging, overdischarging, overcurrent and load short circuiting protection etc. The accurate overcharging detection voltage ensures safe and full utilization charging. The low standby current drains little current from the cell while in storage. The device is not only targeted for digital cellular phones, but also for any other Li-Ion and Li-Poly battery-powered information appliances requiring long-term battery life.

The BRCL3130ZF series product is a high integration solution for lithium-ion/polymer battery protection. BRCL3130ZF contains advanced power MOSFET, high-accuracy voltage detection circuits and delay circuits.

BRCL3130ZF is put into an ultra-small DFN2' 2-6L package and only one external component makes it an ideal solution in limited space of battery pack. BRCL3130ZF has all the protection functions required in the battery application including overcharging, overdischarging, overcurrent and load short circuiting protection etc. The accurate overcharging detection voltage ensures safe and full utilization charging. The low standby current drains little current from the cell while in storage. The device is not only targeted for digital cellular phones, but also for any other Li-Ion and Li-Poly battery-powered information appliances requiring long-term battery life.



- ◆ (1) * 1.5μA typ
- ◆ " f# \$' \$%& "
- ◆ \$
- ◆ I +
- ◆ \$, - . / ~, (. / 0 1.5μA typ
- ◆ Integrate advanced power MOSFET with Equivalent of 50m R_{DS(ON)};
- ◆ Ultra-small DFN2×2-6L package;
- ◆ Over-temperature Protection; Overcharge Current Protection; Two-step Overcurrent Detection: Overdischarge Current; Load Short Circuiting.
- ◆ Charger detection function; 0V battery charging function; delay times are generated inside; High-accuracy voltage detection.
- ◆ Low Current Consumption; Operation Mode: 2.8μA typ; Power-down Mode: 1.5μA typ ; RoHS Compliant and Lead (Pb) Free.
- ◆ Halogen-free Product.



One-Cell lithium-ion battery pack; Lithium-Polymer battery pack.

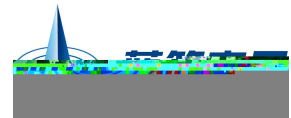

Rev.D Nov.-2020

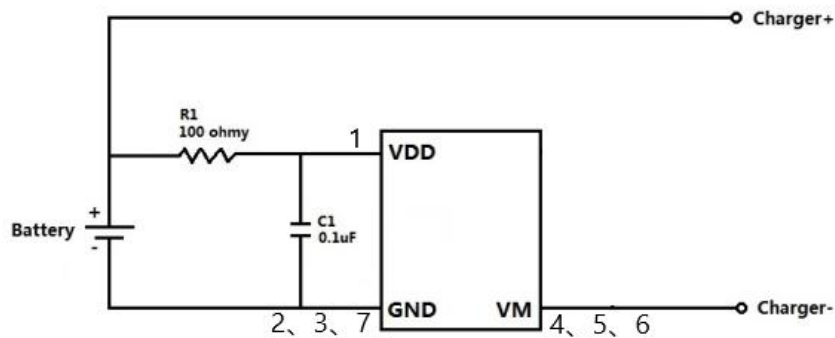

2 3

2 3

Notes:

- (1) The chip power consumption shall not exceed the maximum power consumed by the package.
- (2) This product has anti-static protection function, but do not exceed the maximum capacity of the product to withstand static electricity.

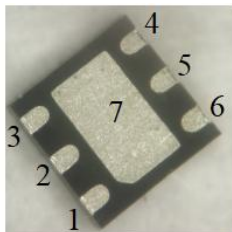

45 # .) 789	45 # :) 8	45 " 8; <95> 5 6
~	VDD	Power Supply
\$. @	GND	Ground, connect the negative terminal of the battery to this pin.
A (&	VM	The negative terminal of the charger. The internal FET switch connects this terminal to GND.

See Marking Instructions.

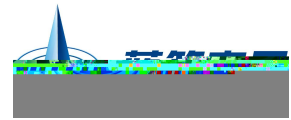

/Parameter	/Symbol	/Value	/Unit
V _{DD} input pin voltage	V _{IN}	-0.3 to +6.0	V
V _M input pin voltage	V _{VM}	-6.0 to +10	V
Maximum Junction Temperature	T _J	125	°C
Lead Temperature	T _L	300	°C
Operating Junction Temperature	T _{opr}	-40 to +85	°C
Storage Temperature	T _{stg}	-55 to +150	°C
Package Thermal Resistance	R _{JA}	250	°C/W
	R _{Jc}	130	°C/W
ESD	ESD	2000	V

/Parameter	/Symbol	/Test Condition	/Min	/Typ	/Max	/Unit
Overcharge Detection Voltage	V _{CU}		4.25	4.30	4.35	V
Overcharge Release Voltage	V _{CL}		4.05	4.10	4.15	V
Overdischarge Detection Voltage	V _{DL}		2.30	2.40	2.50	V
Overdischarge Release Voltage	V _{DR}		2.90	3.00	3.10	V
Charger Detection Voltage	V _{CHA}			-0.12		V
Overdischarge Current1 Detection	I _{IOV1}	V _{dd} =3.5V		3.0		A
Load Short-Circuiting Detection	I _{SHORT}	V _{dd} =3.5V		12		A
Current Consumption in Normal Operation	I _{OPE}	V _{dd} =3.5V, V _M =0V		2.80		μA
Current Consumption in power Down	I _{PDN}	V _{dd} =2V, V _M floating		1.50	6.0	μA
Equivalent FET on Resistance	R _{DS}	V _{dd} =3.6V, I _{VM} =1A		50		m
Over Temperature Protection	T _{SHD+}			120		°C
Over Temperature Recovery Degree	T _{SHD-}			100		°C
Overcharge Voltage Detection Delay Time	T _{CU}	V _{DD} =3.6V~4.4V		128		ms
Overdischarge Voltage Detection Delay Time	T _{DL}	V _{DD} =3.6V~2.0V		32		ms
Overdischarge Current1 Detection Delay Time	T _{IOV1}	V _{DD} =3.6V		8.0		ms
Load Short-Circuiting Detection Delay Time	T _{SHORT}	V _{DD} =3.6V		32		μS

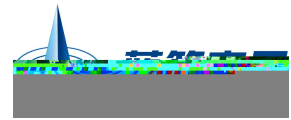

/

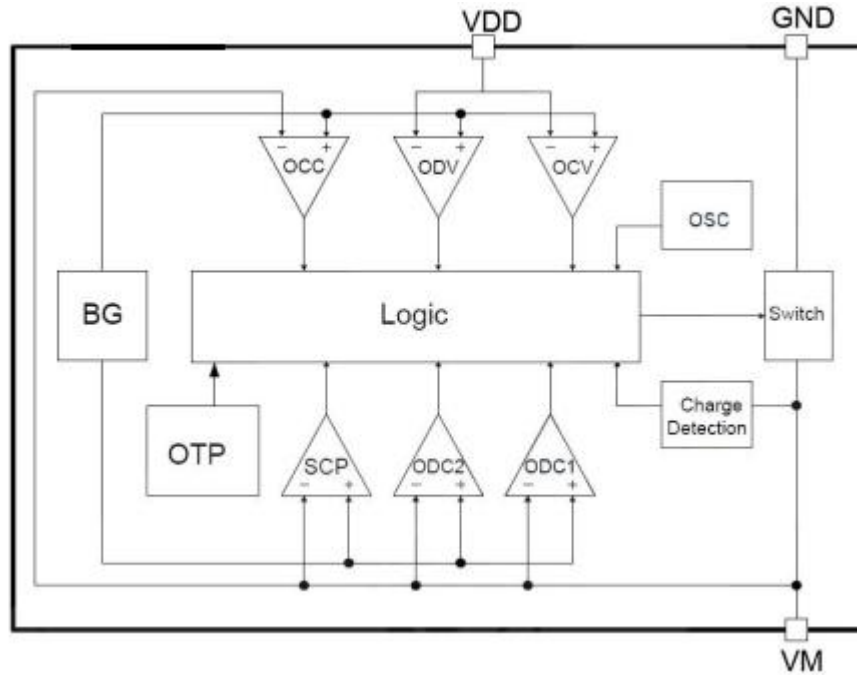

/

BRCL3130ZF

MOSFET

50mΩ

The BRCL3130ZF monitors the voltage and current of a battery and protects it from being damaged due to overcharge voltage, overdischarge voltage, overdischarge current, and short circuit conditions by disconnecting the battery from the load or charger. The peripheral circuit is very simple. The MOSFET is integrated and its $R_{DS(ON)}$ is as low as 50mΩ typical.

/

If no exception condition is detected, charging and discharging can be carried out freely. This condition is called the normal operating mode.

/

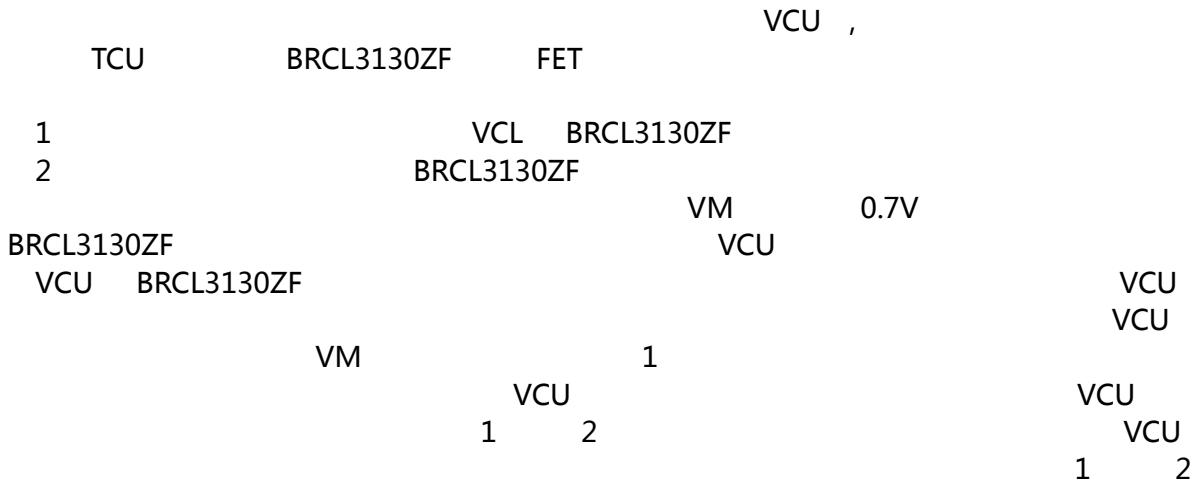
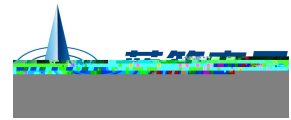

When the battery voltage becomes higher than the overcharge detection voltage (VCU) during charging under normal condition and the state continues for the overcharge detection delay time (TCU) or longer, the BRCL3130ZF turns the charging control FET off to stop charging. This condition is called the overcharge condition.

The overcharge condition is released in the following two cases:

1 When the battery voltage drops below the overcharge release voltage (VCL), the BRCL3130ZF turns the charging control FET on and returns to the normal condition.

2 When a load is connected and discharging starts, the BRCL3130ZF turns the charging control FET on and returns to the normal condition. The release mechanism is as follows: the discharging current flows through an internal parasitic diode of the charging FET immediately after a load is connected and discharging starts, and the VM pin voltage increases about 0.7 V (forward voltage of the diode) from the GND pin voltage momentarily. The BRCL3130ZF detects this voltage and releases the overcharge condition. Consequently, in the case that the battery voltage is equal to or lower than the overcharge detection voltage (VCU), the BRCL3130ZF returns to the normal condition immediately, but in the case the battery voltage is higher than the overcharge detection voltage (VCU), the chip does not return to the normal condition until the battery voltage drops below the overcharge detection voltage (VCU) even if the load is connected. In addition, if the VM pin voltage is equal to or lower than the overcurrent 1 detection voltage when a load is connected and discharging starts, the chip does not return to the normal condition.

Note: If the battery is charged to a voltage higher than the overcharge detection voltage (VCU) and the battery voltage does not drop below the overcharge detection voltage (VCU) even when a heavy load, which causes an overcurrent, is connected, the overcurrent 1 and overcurrent 2 do not work until the battery voltage drops below the overcharge detection voltage (VCU). Since an actual battery has, however, an internal impedance of several dozens of mΩ, and the battery voltage drops immediately after a heavy load which causes an overcurrent is connected, the overcurrent 1 and overcurrent 2 work. Detection of load shortcircuiting works regardless of the battery voltage.

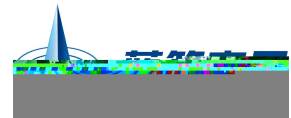

/

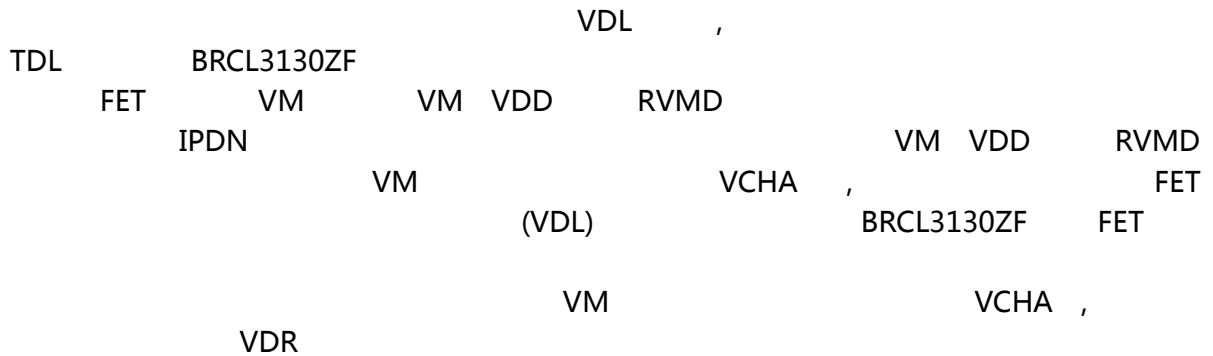

When the battery voltage drops below the overdischarge detection voltage (VDL) during discharging under normal condition and it continues for the overdischarge detection delay time (tDL) or longer, the BRCL3130ZF turns the discharging control FET off and stops discharging. This condition is called overdischarge condition. After the discharging control FET is turned off, the VM pin is pulled up by the RVMD resistor between VM and VDD in BRCL3130ZF the current of the chip is reduced to the power-down current (IPDN). This condition is called power-down condition. The VM and VDD pins are shorted by the RVMD resistor. The power-down condition is released when a charger is connected and the potential difference between VM and VDD becomes typical or higher, at this time, the FET is still off. When the battery voltage becomes the overdischarge detection voltage (VDL) or higher (see note), the BRCL3130ZF turns the FET on and changes to the normal condition from the overdischarge condition. Note: If the VM pin voltage is no less than the charger detection voltage (VCHA), when the battery under overdischarge condition is connected to a charger, the overdischarge condition is released (the discharging control FET is turned on) as usual, provided that the battery voltage reaches the overdischarge release voltage (VDR) or higher.

/



1
When the discharging current becomes equal to or higher than a specified value (the VM pin voltage is

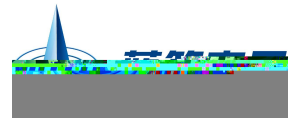

VM (VCHA)
(TCU) BRCL3130ZF FET
VM GND (VCHA) 0V 0V
0V

If the VM pin voltage drops below the charger detection voltage (VCHA) during charging under the normal condition and it continues for the overcharge detection delay time (TCU) or longer, the BRCL3130ZF turns the charging control FET off and stops charging. This action is called abnormal charge current detection.

Abnormal charge current detection is released when the voltage difference between VM pin and GND pin becomes higher than the charger detection voltage (VCHA) eTee x co

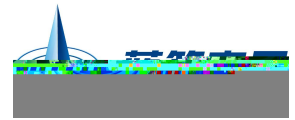

/

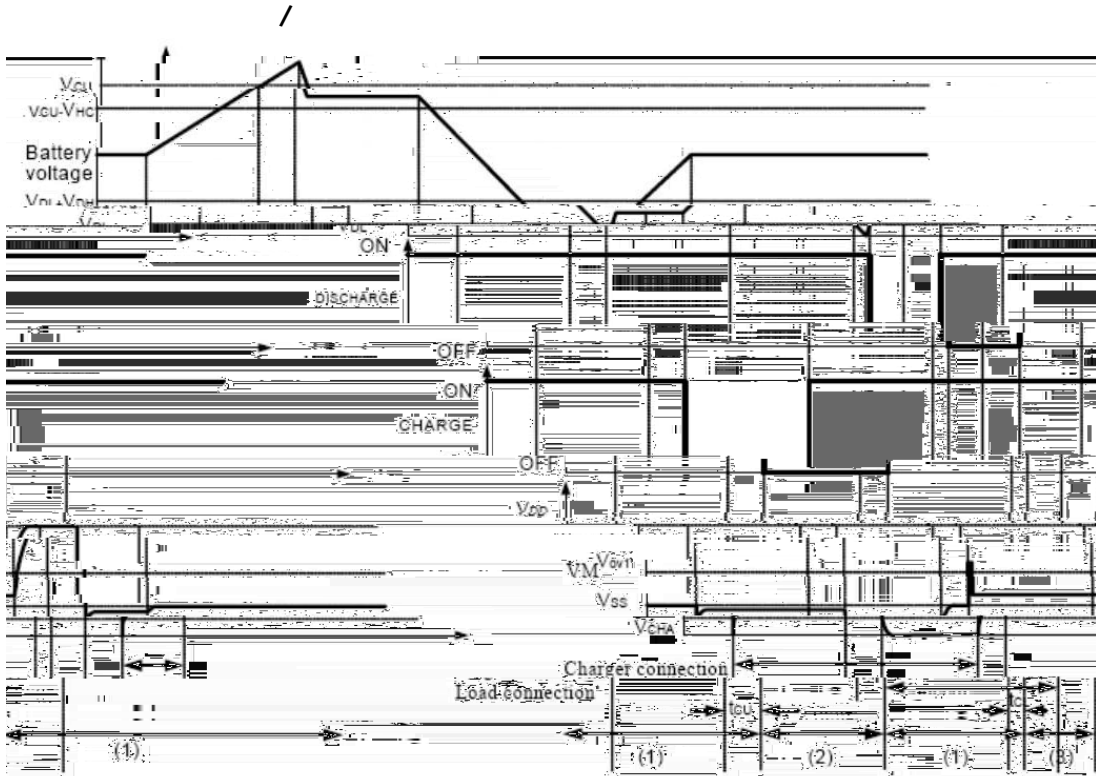

/

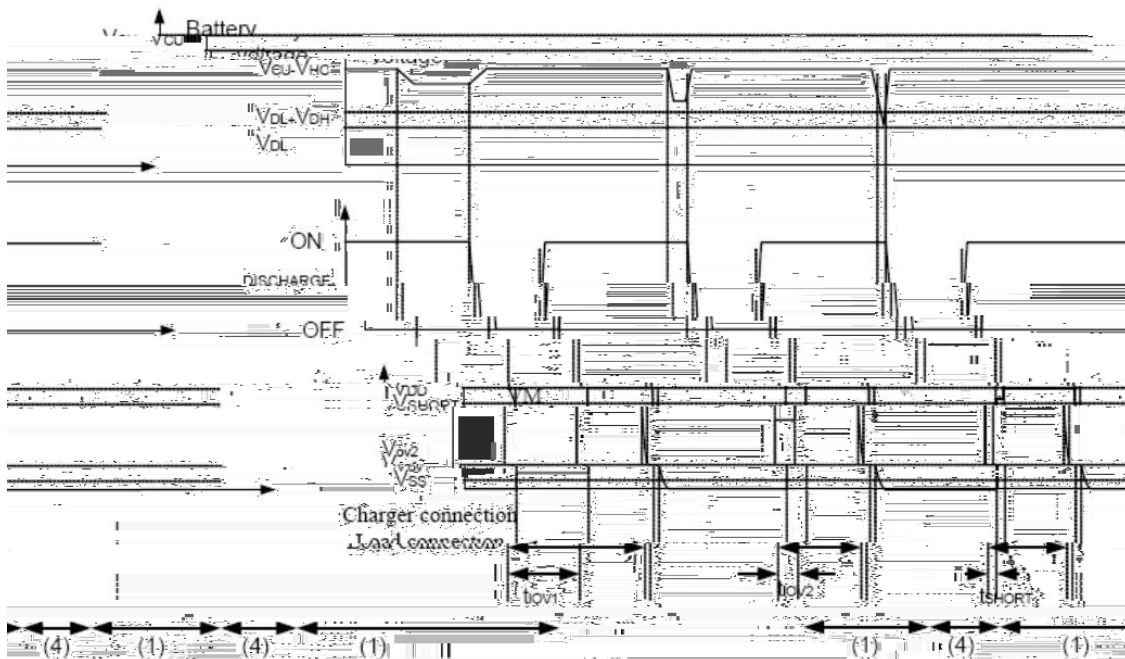

/

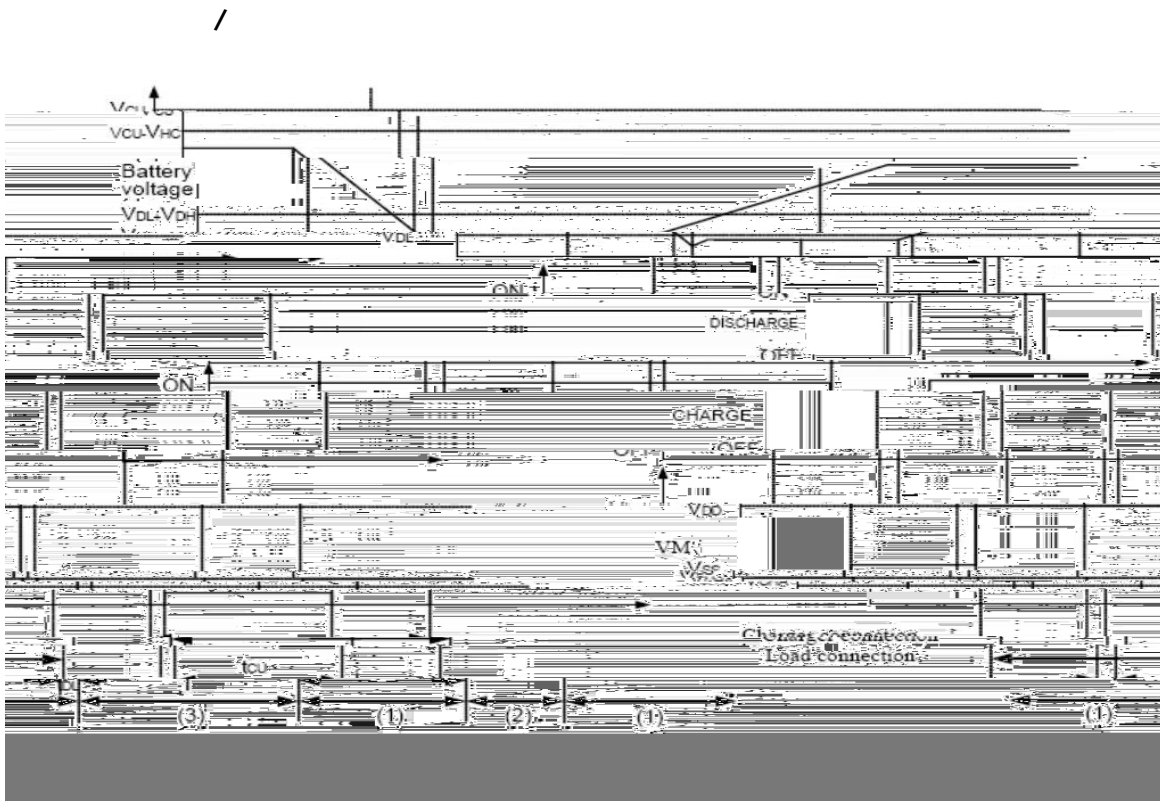
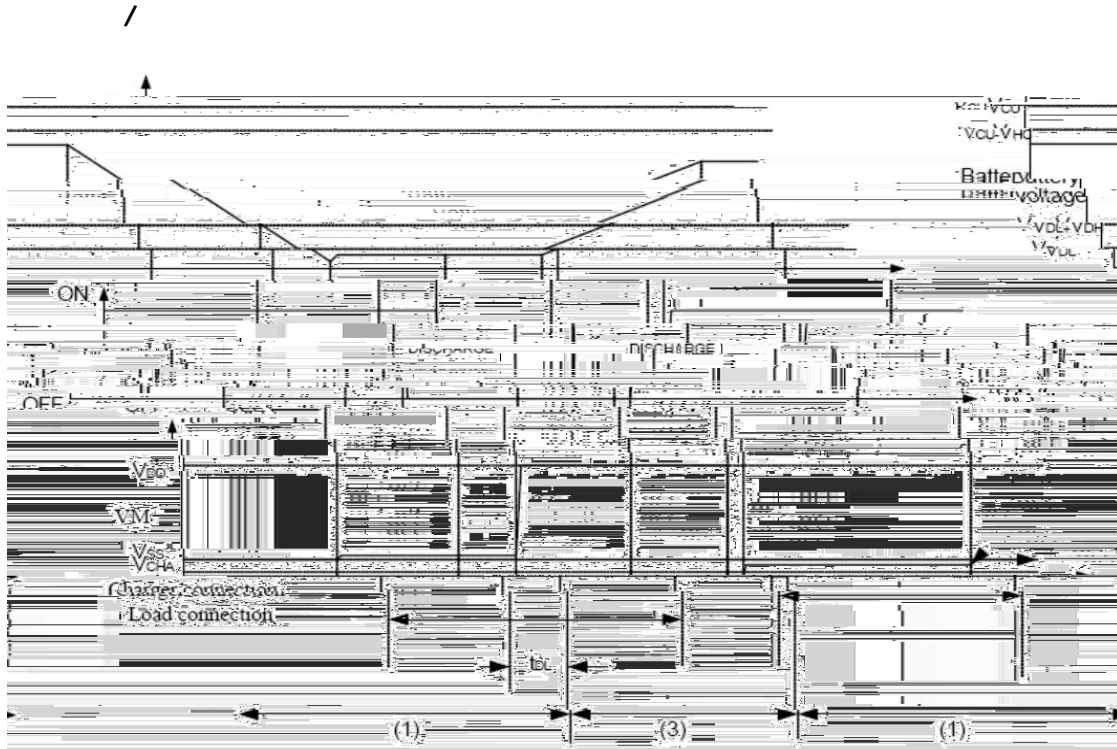
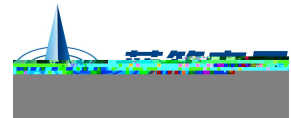

Notes: (1) Normal condition (2) Overcharge voltage condition (3) Overdischarge voltage condition (4) Overcurrent condition

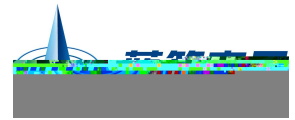

DFN2x2-6L-0.5

Unit:mm

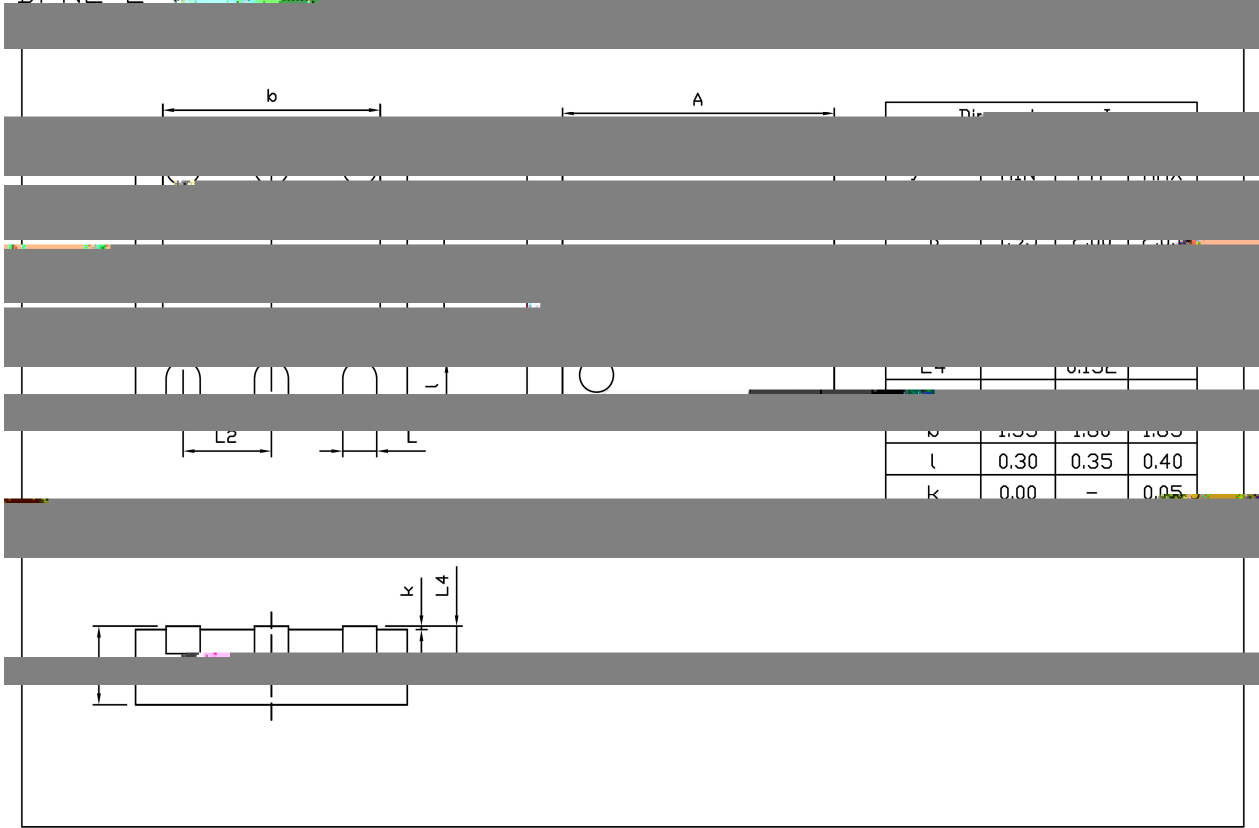

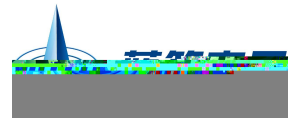

正面俯视图

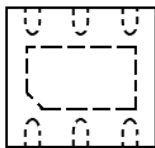

正面透视图

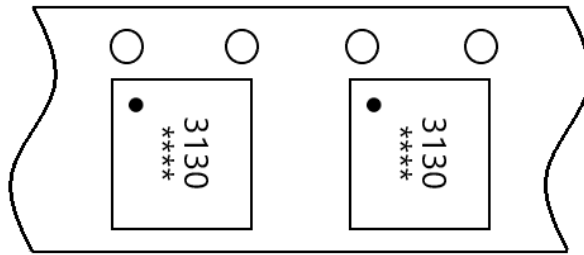

编带示意图

3130

Note:

3130:

Product Type.

****:

Lot No. Code, code change with Lot No.

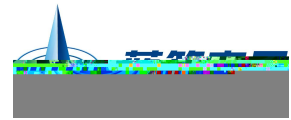

Temperature Profile for IR Reflow Soldering(Pb-Free)

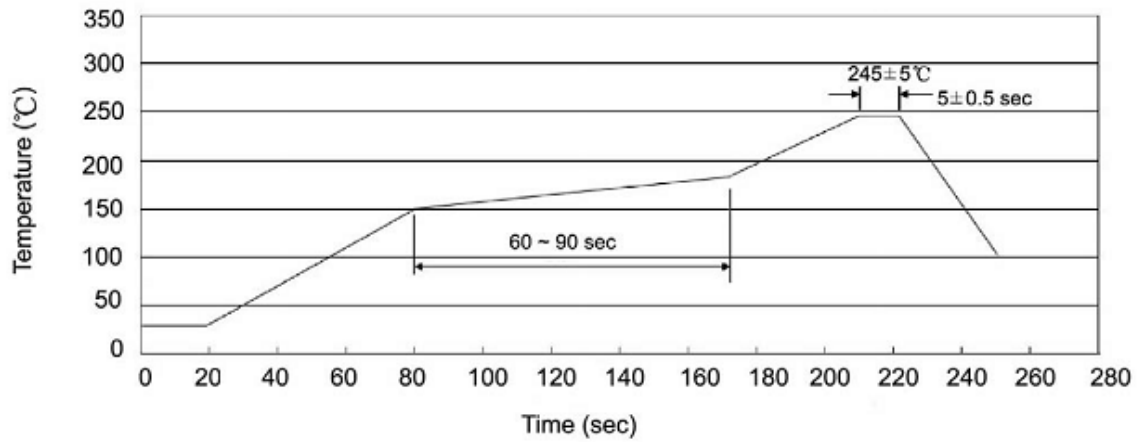

说明：

- 1、预热温度 150 ~ 180°C，时间 60 ~ 90sec;
- 2、峰值温度 245±5°C，时间持续为 5±0.5sec;
- 3、焊接制程冷却速度为 2 ~ 10°C/sec.

Note:

- 1.Preheating:150~180°C, Time:60~90sec.
- 2.Peak Temp.:245±5°C, Duration:5±0.5sec.
3. Cooling Speed: 2~10°C/sec.

温度：260±5°C

时间：10±1 sec.

Temp.:260±5°C

Time:10±1 sec

卷盘包装 / REEL

Package Type 封装形式	Units 包装数量					Dimension 包装尺寸 (unit : mm ³)		
	Units/Reel 只/卷盘	Reels/Inner Box 卷盘/盒	Units/Inner Box 只/盒	Inner Boxes/Outer Box 盒/箱	Units/Outer Box 只/箱	Reel	Inner Box 盒	Outer Box 箱
DFN 2x2-3L/6L	4,000	10	40,000	4	160,000	7" × 8	210×210×205	445×445×230