

/ Descriptions

BRCL3230DZN	/	BRCL3230DZN
	MOSFET	
BRCL3230DZN	DFN1×1-4L	
	BRCL3230DZN	

The BRCL3230DZN series product is a high integration solution for lithium-ion/polymer battery protection. BRCL3230DZN contains advanced power MOSFET, high-accuracy voltage detection circuits and delay circuits.

BRCL3230DZN is put into an ultra-small DFN1×1-4L package and only one external component makes it an ideal solution in limited space of battery pack. BRCL3230DZN has all the protection functions required in the battery application including overcharging, overdischarging, overcurrent and load short circuiting protection etc. The accurate overcharging detection voltage ensures safe and full utilization charging. The low standby current drains little current from the cell while in storage. The device is not only targeted for digital cellular phones, but also for any other Li-Ion and Li-Poly battery-powered information appliances requiring long-term battery life.

/ Features

- ◆ 60m MOSFET
- ◆ RC
- ◆ DFN1×1-4L
- ◆
- ◆ OV
- ◆ 2.5uA < 0.1uA;
- ◆
- ◆
- ◆ Integrate advanced power MOSFET with Equivalent of 60m $R_{DS(ON)}$;
- ◆ Internal integration RC without any peripheral devices;
- ◆ Ultra-small DFN1×1-4L package;
- ◆ Over-temperature Protection; Overcharge Current Protection; Overdischarge Current Protection; Load Short Circuiting Protection;
- ◆ Charger detection function; 0V battery charging function; delay times are generated inside; High-accuracy voltage detection.
- ◆ Low Current Consumption; Operation Mode: 2.5μA typ; Power-down Mode: <0.1uA typ ;
- ◆ The Overdischarge is not self recovery and needs to be activated;
- ◆ HF Product.

/ Applications

One-Cell lithium-ion battery pack; Lithium-Polymer battery pack.

/ Typical Application

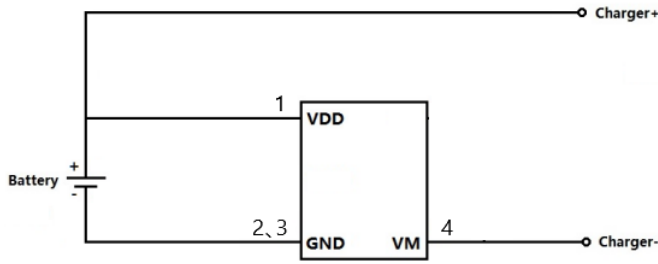

/ Pinning

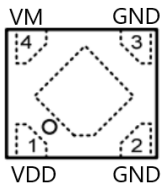

Pin Number	Pin Name	Pin Description
1	VDD	Power Supply
2 3	GND	Ground, connect the negative terminal of the battery to this pin.
4	VM	The negative terminal of the charger. The internal FET switch connects this terminal to GND.

/ Marking

See Marking Instructions.

/ Absolute Maximum Ratings(Ta=25)

/Parameter	/Symbol	/Value	/Unit
V _{DD} input pin voltage	V _{IN}	-0.3 to +6	V
V _M input pin voltage	V _{VM}	-9 to +9	V
Maximum Junction Temperature	T _J	125	
Operating Junction Temperature	T _{opr}	-40 to +85	°C
Storage Temperature	T _{stg}	-55 to +150	°C
Package Thermal Resistance	R _{JA}	250	°C/W
ESD HBM	ESD	2000	V

/ Electrical Characteristics(Ta=25)

/Parameter	/Symbol	/Test Condition	/Min	/Typ	/Max	/Unit
Overcharge Detection Voltage	V _{CU}		4.25	4.30	4.35	V
Overcharge Release Voltage	V _{CL}		4.05	4.10	4.15	V
Overdischarge Detection Voltage	V _{DL}		2.70	2.80	2.90	V
Overdischarge Release Voltage	V _{DR}		2.90	3.00	3.10	V
Charger Detection Voltage	V _{CHA}		-0.3	-0.4	-0.5	V
Overcharge Current Detection	I _{IOCC}	V _{dd} =3.6V	0.4	0.7	1.0	A
Overdischarge Current1 Detection	I _{IOV1}	V _{dd} =3.6V	0.4	0.7	1.0	A
Load Short-Circuiting Detection	I _{SHORT}	V _{dd} =3.6V	6	12	18	A
Current Consumption in Normal Operation	I _{OPE}	V _{dd} =3.6V, V _M =0V		2.5	3.5	μA
Current Consumption in power Down	I _{PDN}	V _{dd} =2V, V _M floating			0.1	μA
Equivalent FET on Resistance	R _{DS}	V _{dd} =3.6V, I _{VM} =0.3A		60		m
Over Temperature Protection	T _{SHD+}			140		°C
Over Temperature Recovery Degree	T _{SHD-}			115		°C
Overcharge Current Detection Delay Time	T _{OCC}	V _{dd} =3.6V	7	9	11	ms
Overcharge Voltage Detection Delay Time	T _{CU}	V _{dd} =3.6V~4.4V	100	150	200	ms
Overdischarge Voltage Detection Delay Time	T _{DL}	V _{dd} =3.6V~2.0V	30	40	50	ms
Overdischarge Current1 Detection Delay Time	T _{IOV1}	V _{dd} =3.6V	7	9	11	ms
Load Short-Circuiting Detection Delay Time	T _{SHORT}	V _{dd} =3.6V		100	300	us

Functional Block Diagram

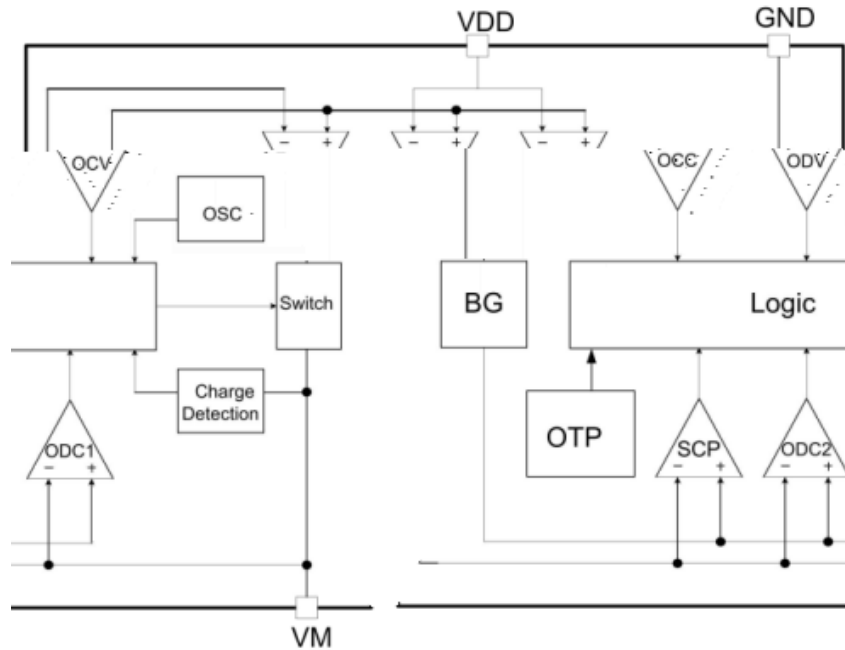

Functional Description

BRCL3230DZN

MOSFET

60m

The BRCL3230DZN monitors the voltage and current of a battery and protects it from being damaged due to overcharge voltage, overdischarge voltage, overdischarge current, and short circuit conditions by disconnecting the battery from the load or charger. The peripheral circuit is very simple. The MOSFET is integrated and its $R_{DS(ON)}$ is as low as 60m typical.

Normal Operating mode

If no exception condition is detected, charging and discharging can be carried out freely. This condition is called the normal operating mode.

Overcharge Condition

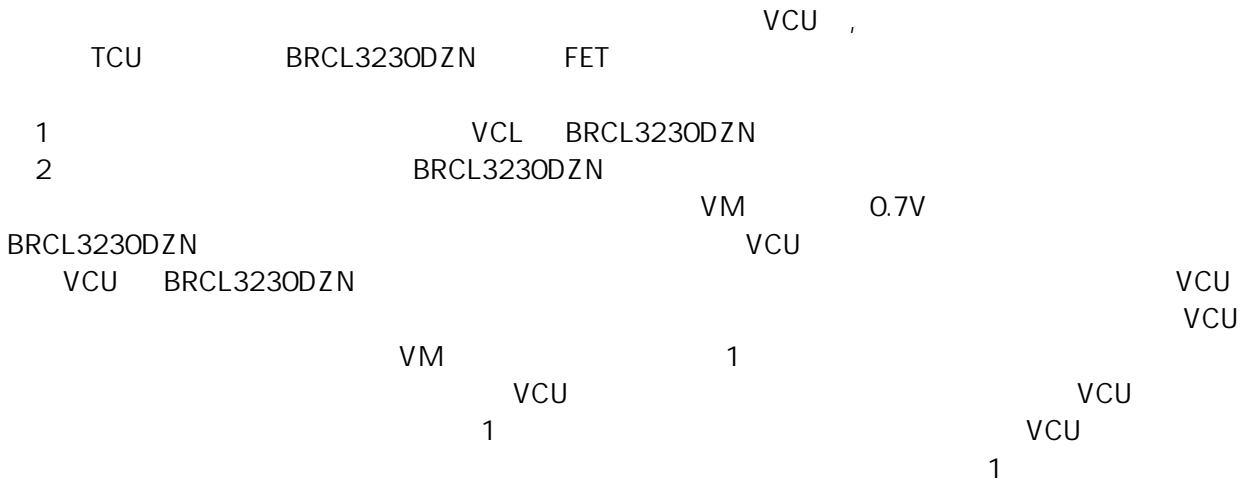

When the battery voltage becomes higher than the overcharge detection voltage (VCU) during charging under normal condition and the state continues for the overcharge detection delay time (TCU) or longer, the BRCL3230DZN turns the charging control FET off to stop charging. This condition is called the overcharge condition.

The overcharge condition is released in the following two cases:

1 When the battery voltage drops below the overcharge release voltage (VCL), the BRCL3230DZN turns the charging control FET on and returns to the normal condition.

2 When a load is connected and discharging starts, the BRCL3230DZN turns the charging control FET on and returns to the normal condition. The release mechanism is as follows: the discharging current flows through an internal parasitic diode of the charging FET immediately after a load is connected and discharging starts, and the VM pin voltage increases about 0.7 V (forward voltage of the diode) from the GND pin voltage momentarily. The BRCL3230DZN detects this voltage and releases the overcharge condition. Consequently, in the case that the battery voltage is equal to or lower than the overcharge detection voltage (VCU), the BRCL3230DZN returns to the normal condition immediately, but in the case the battery voltage is higher than the overcharge detection voltage (VCU), the chip does not return to the normal condition until the battery voltage drops below the overcharge detection voltage (VCU) even if the load is connected. In addition, if the VM pin voltage is equal to or lower than the overcurrent 1 detection voltage when a load is connected and discharging starts, the chip does not return to the normal condition.

Note: If the battery is charged to a voltage higher than the overcharge detection voltage (VCU) and the battery voltage does not drop below the overcharge detection voltage (VCU) even when a heavy load, which causes an overcurrent, is connected, the overcurrent 1 does not work until the battery voltage drops below the overcharge detection voltage (VCU). Since an actual battery has, however, an internal impedance of several dozens of mΩ, and the battery voltage drops immediately after a heavy load which causes an overcurrent is connected, the overcurrent 1 works. Detection of load shortcircuiting works regardless of the battery voltage.

Abnormal Charge Current Detection

VM		I _{occ}	
BRCL3230DZN	FET	(VCHA)	OV
VM GND			

If the VM pin voltage drops below the Overcharge Current Detection during charging under the normal condition and it continues for the overcharge detection delay time or longer, the BRCL3230DZN turns the charging control FET off and stops charging. This action is called abnormal charge current detection.

Abnormal charge current detection is released when the voltage difference between VM pin and GND pin becomes higher than the charger detection voltage (VCHA) by separating the charger. Since the 0 V battery charging function has higher priority than the abnormal charge current detection function, abnormal charge current may not be detected by the product with the 0 V battery charging function while the battery voltage is low.

Load Short-circuiting Condition

VM	VSHORT	tSHORT
BRCL3230DZN	VM	VSHORT

If voltage of VM pin is higher short circuiting protection voltage (VSHORT) and it continues for the tSHORT or longer, the BRCL3230DZN will stop discharging and battery is disconnected from load. This status is released when voltage of VM pin is higher than short protection voltage (VSHORT), such as when disconnecting the load.

0V Battery Charging Function

	OV	VDL	IC
(1)	"	OV	"
(2)"	OV	"	"
	IC		VDL
(3)	VM	GND	VM GND

This function enables the charging of a connected battery whose voltage is 0V by self-discharge. When connects to a charger , the discharging control FET is off and the charging current flows through the internal parasitic diode in the discharging control FET. If the battery voltage becomes equal to or higher than the overdischarge release voltage (VDL), the normal condition returns.

Notes (1) Some battery providers do not recommend charging of completely discharged batteries. Please refer to battery providers before the selection of 0 V battery charging function.

(2) The 0V battery charging function has higher priority than the abnormal charge current detection function. Consequently, a product with the 0 V battery charging function charges a battery and abnormal charge current cannot be detected during the battery voltage is low.

(3) When a battery is connected to the IC for the first time, the IC may not enter the normal condition in which discharging is possible. In this case, set the VM pin voltage equal to the GND voltage (short the VM and GND pins or connect a charger) to enter the normal condition.

Timing Chart

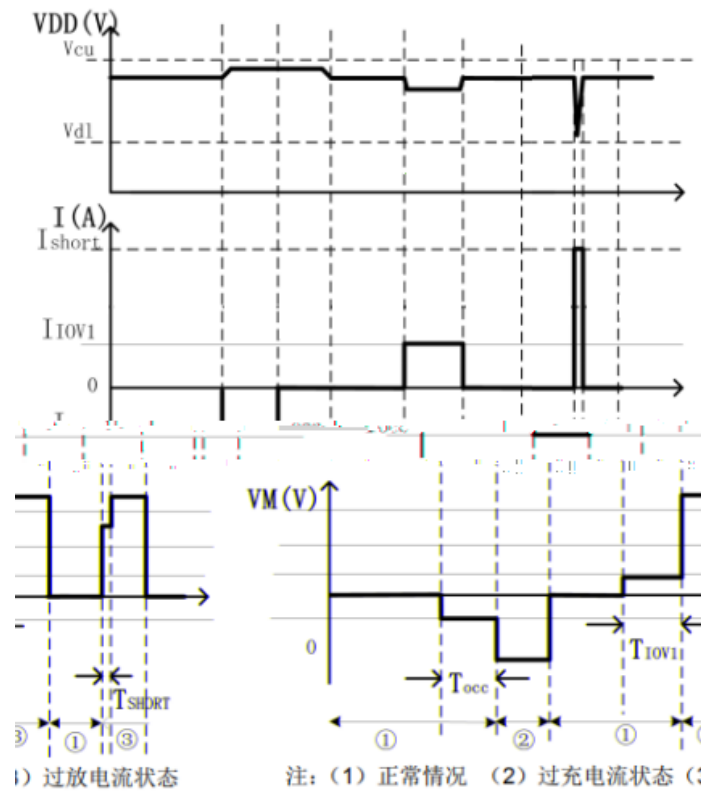
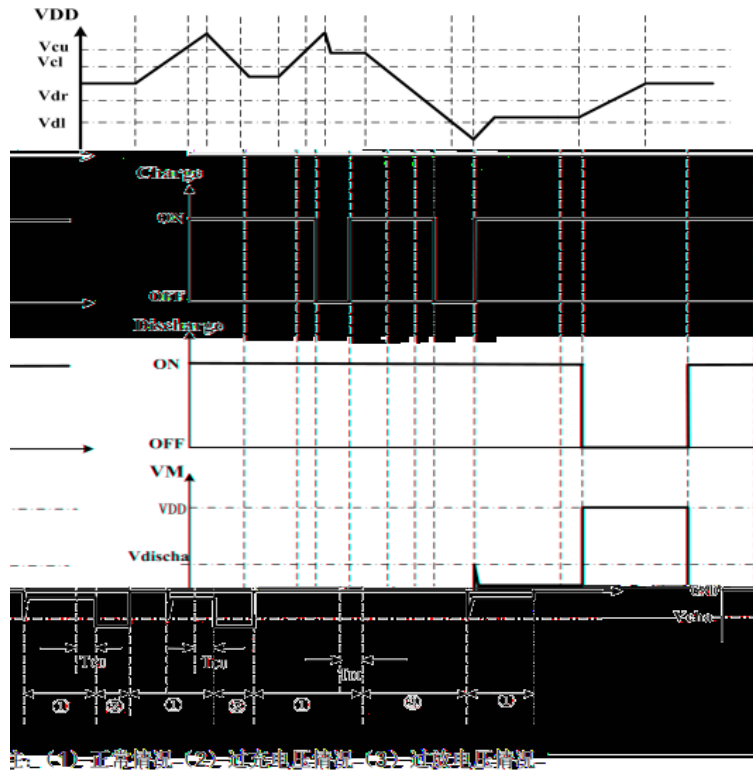

Timing Chart

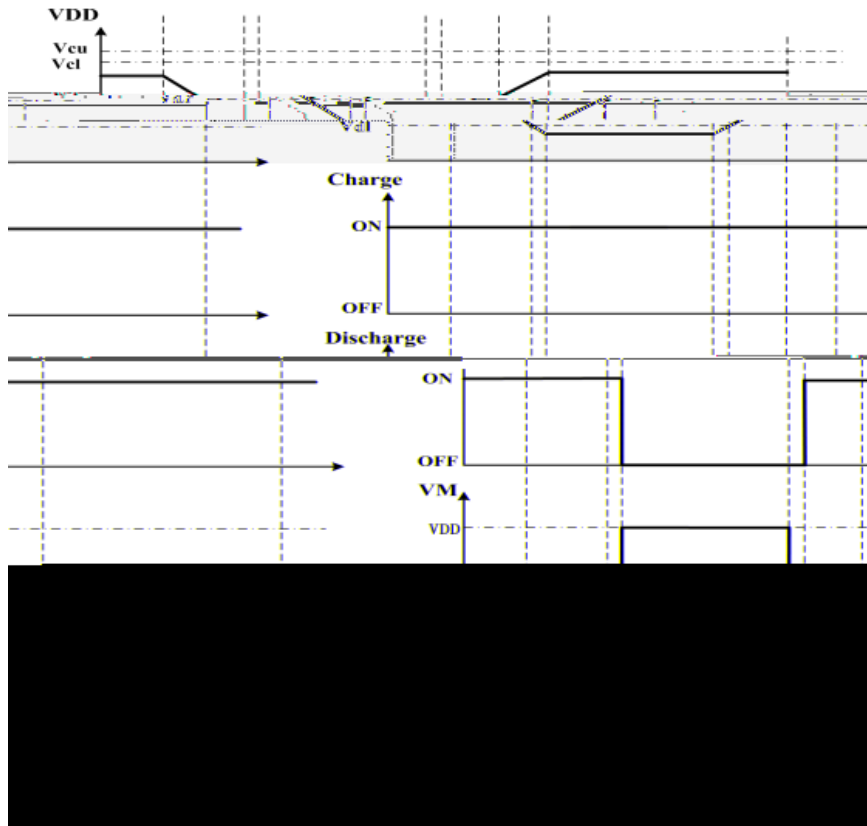

/ Package Dimensions

DFN1X1-4L-A

Unit:mm

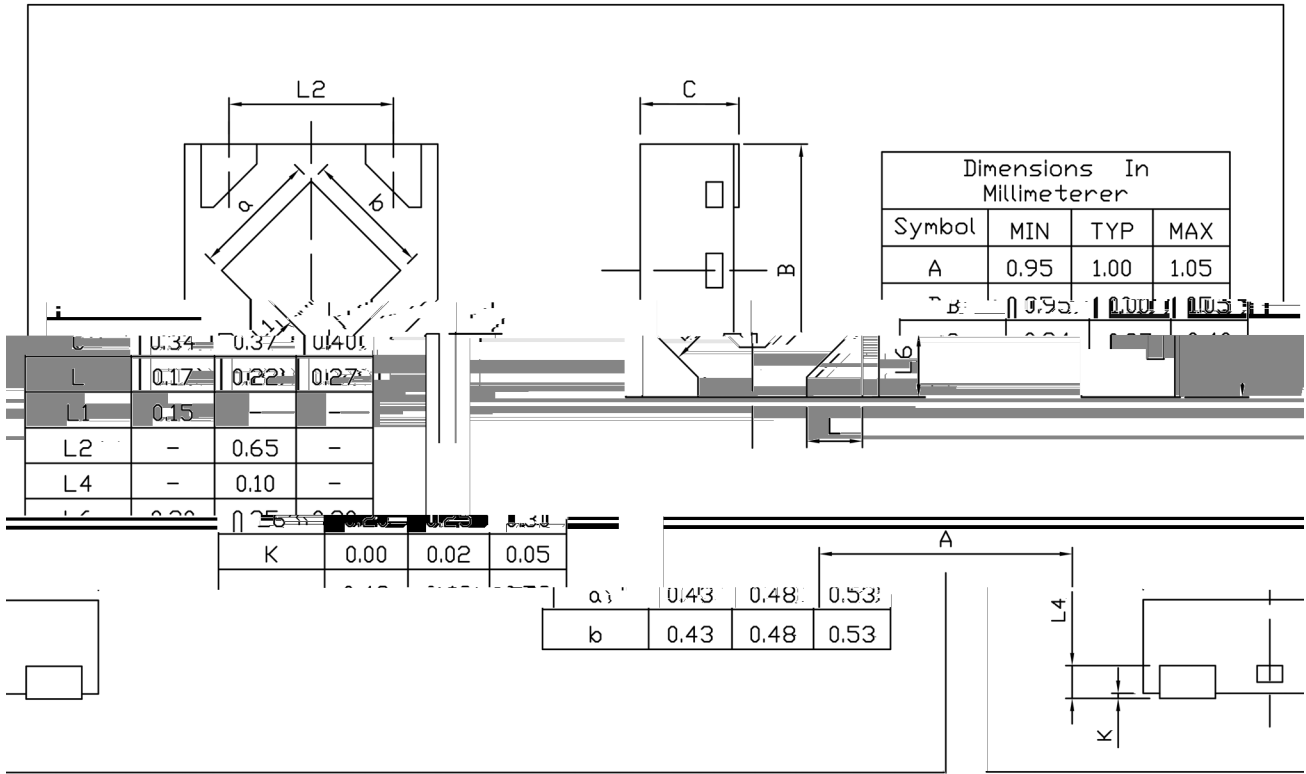

Rev.00 201910

/ Marking Instructions

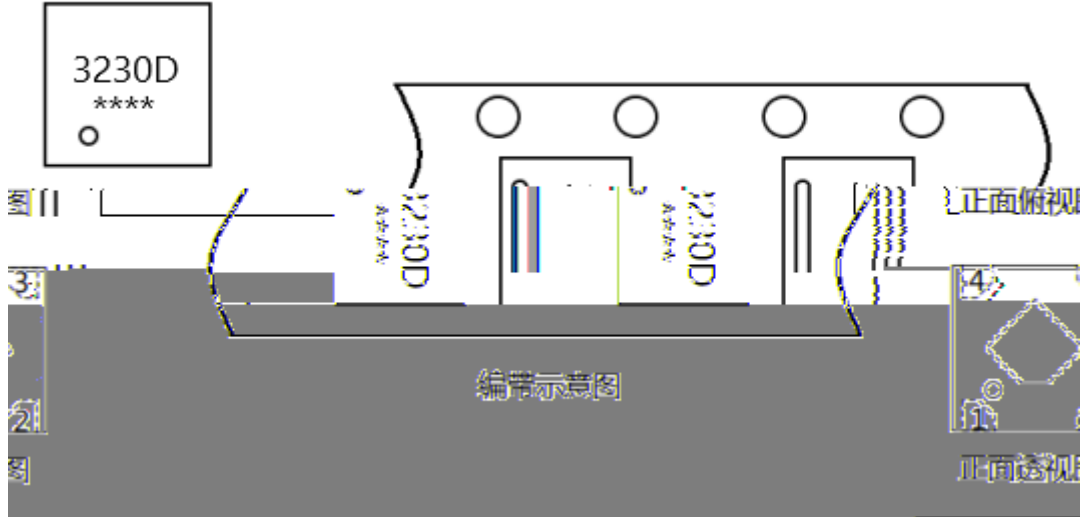

3230D

Note:

3230D: Product Type

****: Lot No. Code, code change with Lot No

() /

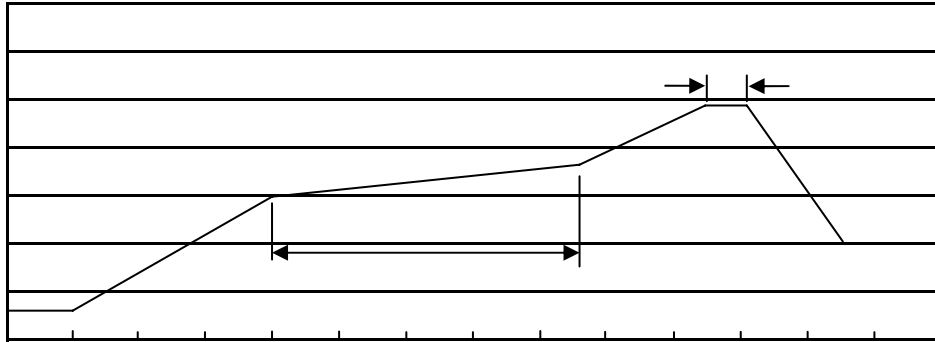

Note:

- | | | | |
|---|---------|-----------|---|
| 1 | 150 180 | 60 90sec; | 1.Preheating:150~180 , Time:60~90sec. |
| 2 | 245±5 | 5±0.5sec; | 2.Peak Temp.:245±5 , Duration:5±0.5sec. |
| 3 | 2 10 | /sec. | 3. Cooling Speed: 2~10 /sec. |

/ Resistance to Soldering Heat Test Conditions

260±5 10±1 sec. Temp.:260±5 Time:10±1 sec

/ Packaging SPEC.

/ REEL

Package Type	Units					Dimension (unit mm ³)		
	Units/Reel /	Reels/Inner Box /	Units/Inner Box /	Inner Boxes/Outer Box /	Units/Outer Box /	Reel	Inner Box	Outer Box
DFN 1×1-4L/6L	10,000	10	100,000	4	400,000	7 × 8	210×205×205	445×230×435

/ Notices