

BRCO7533TAQ

/ Absolute Maximum Ratings(Ta=25)

/ Electrical Characteristics(Ta=25)

						μ

/ Electrical Characteristic Curve

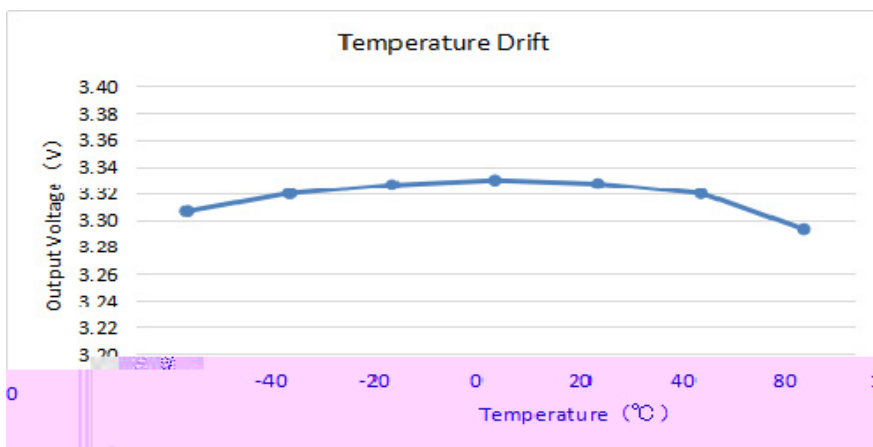
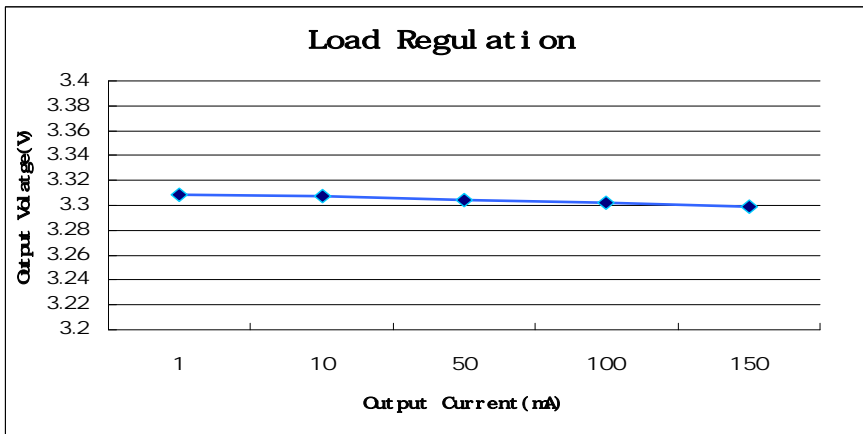
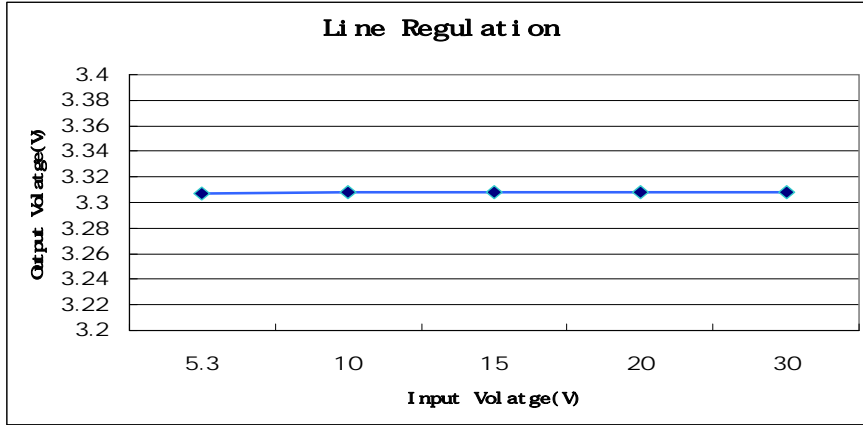

/ Typical Application Circuit

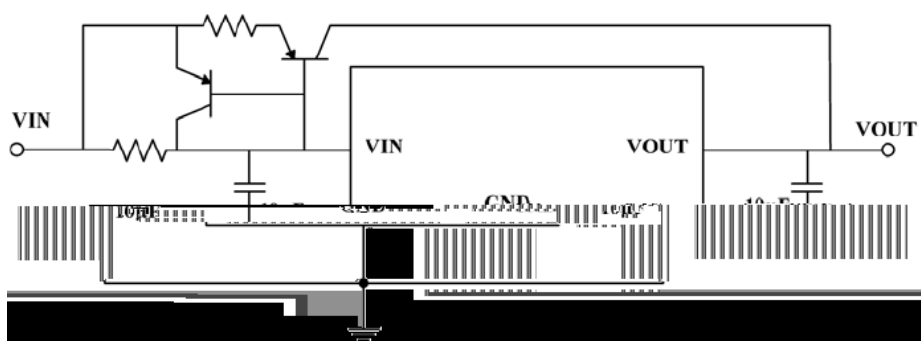
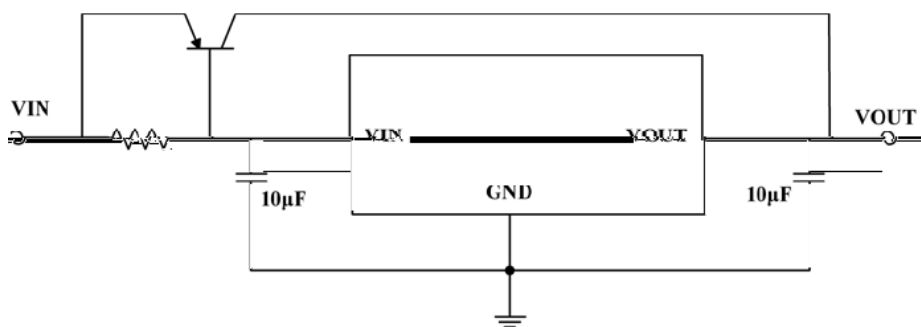
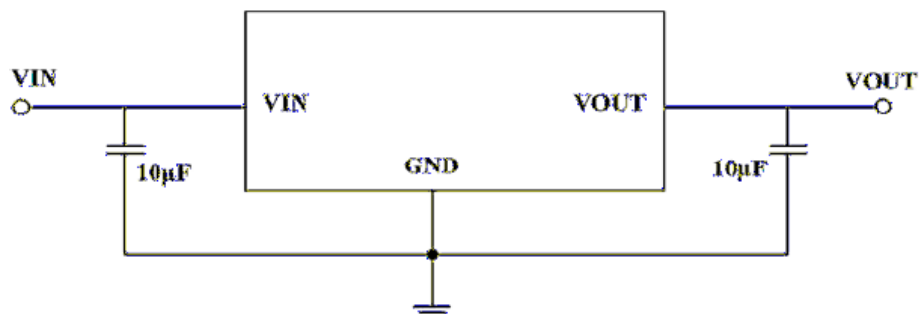

/ Typical Application Circuit

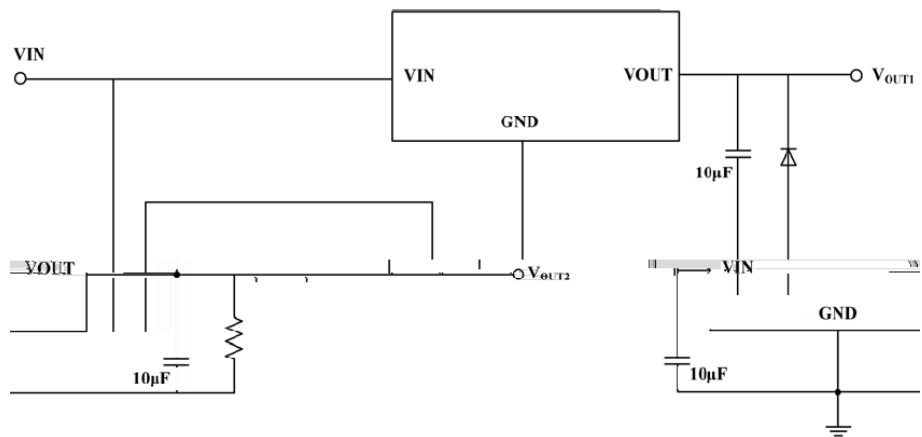
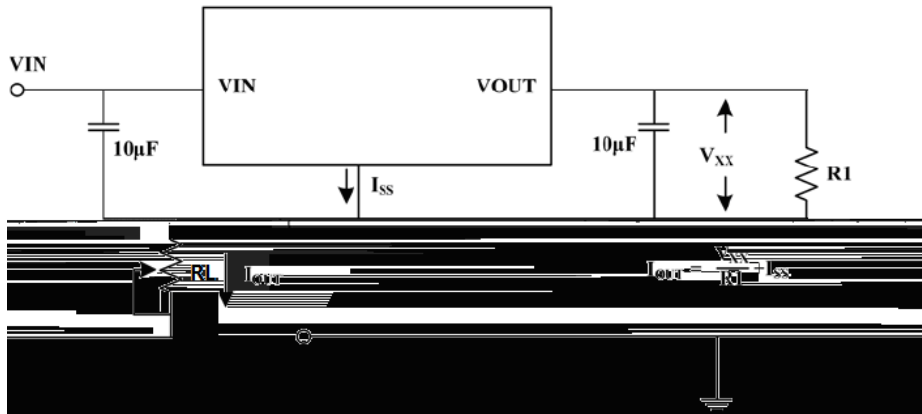
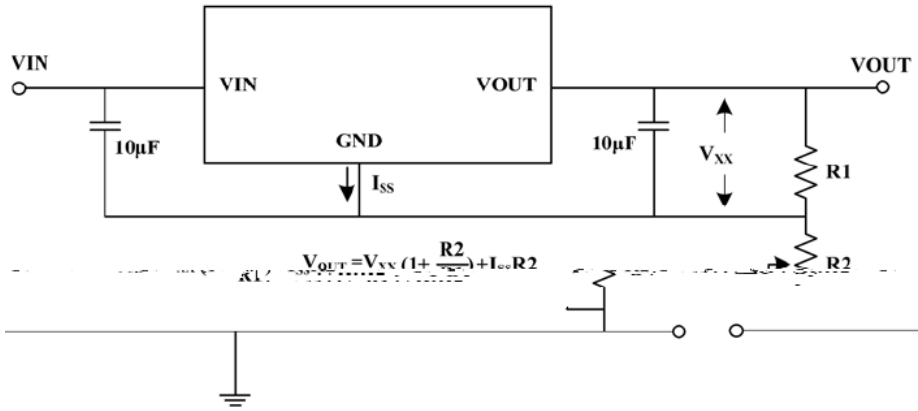

/ Package Dimensions

SMT-89

单位: mm

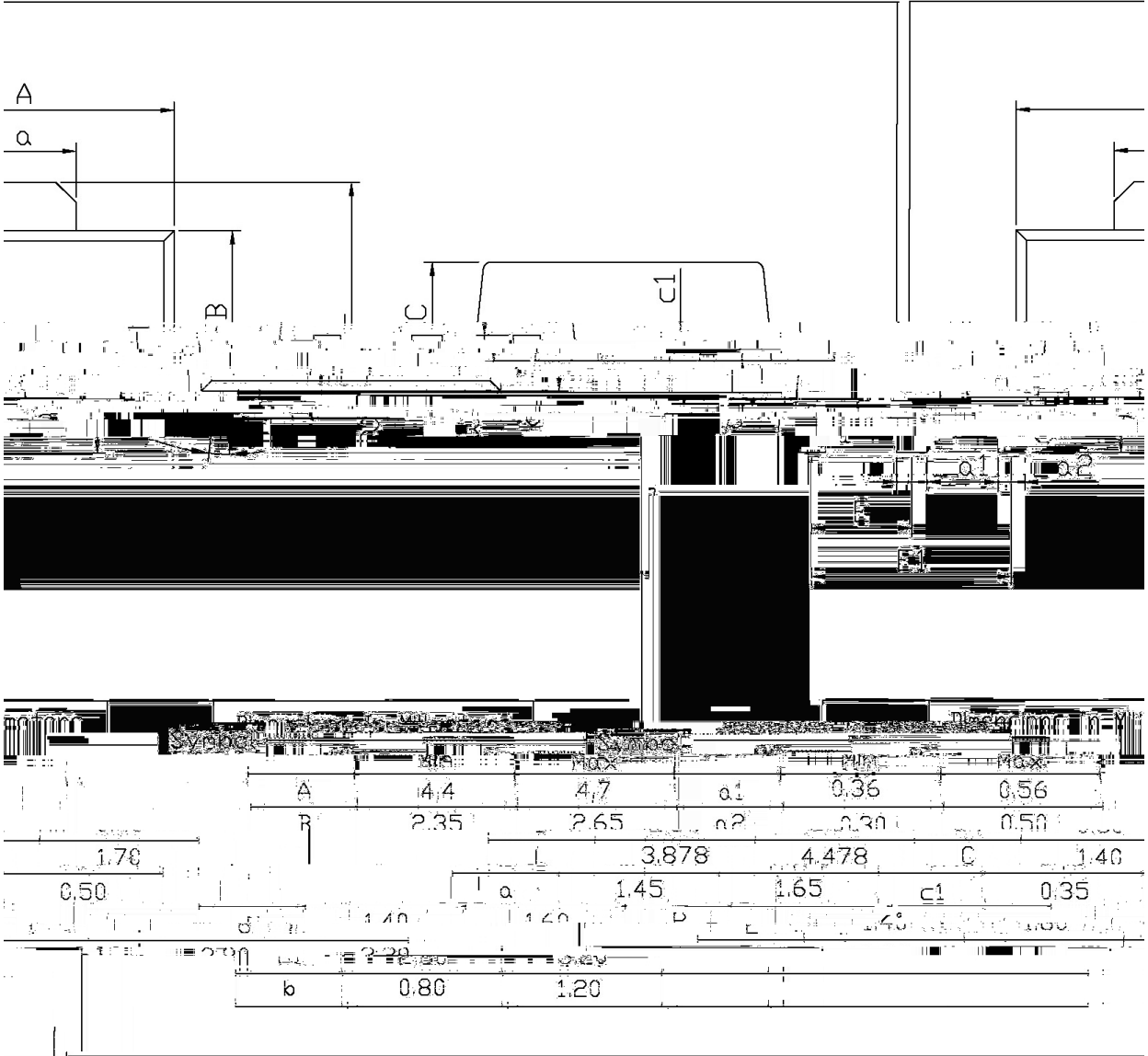

/ Marking Instructions

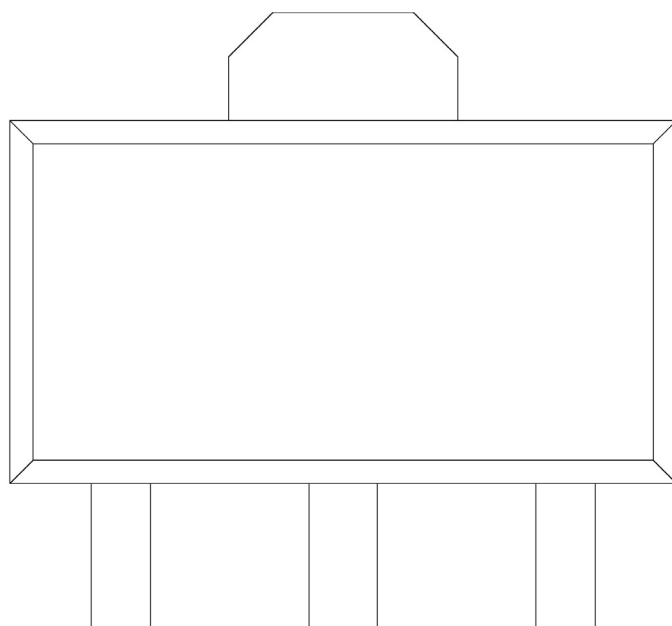

**

() / Temperature Profile for IR Reflow Soldering(Pb-Free)

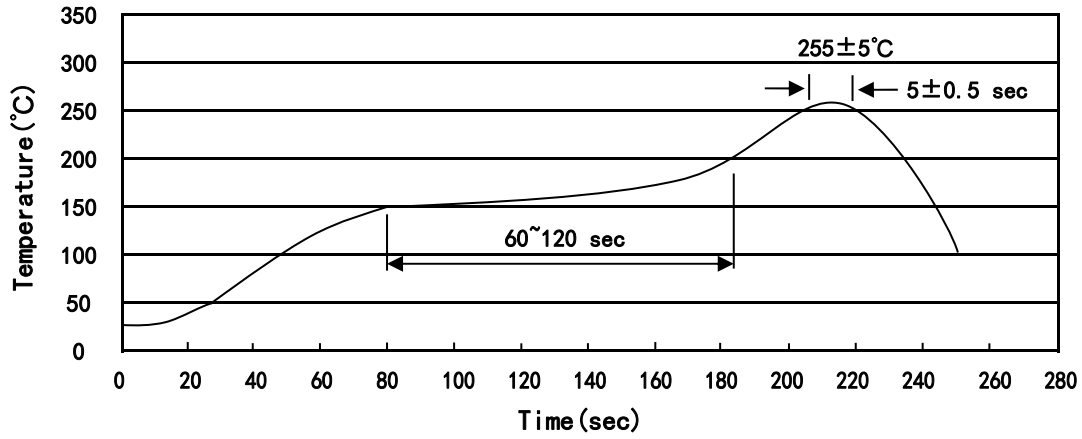

± ± ± ±

/ Resistance to Soldering Heat Test Conditions

± ±

/ Packaging SPEC.

/ Notices