

BRC07550MT

/ Descriptions

SOT-89

/ Features

24V

1.5 μ A

$\pm 2\%$

μ

$\pm 2\%$

/ Applications

/ Equivalent Circuit

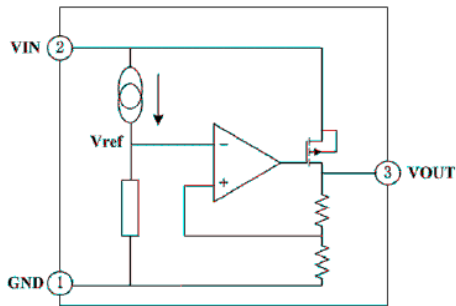

/ Pinning

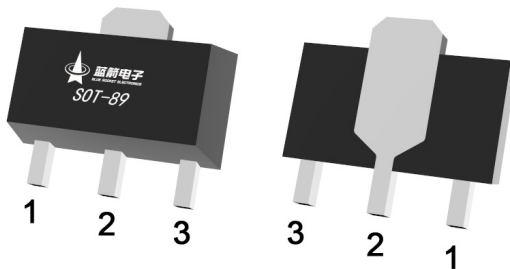

/ Marking

BRCO7550MT



DATA SHEET

	θ		$^{\circ}\text{C}$

/ Typical Application Circuit

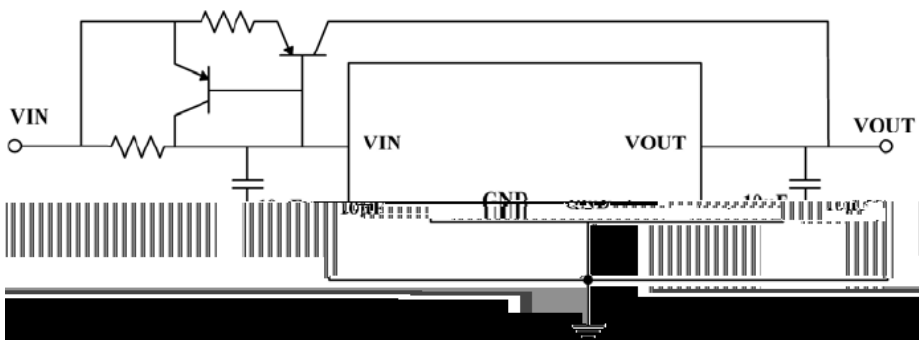
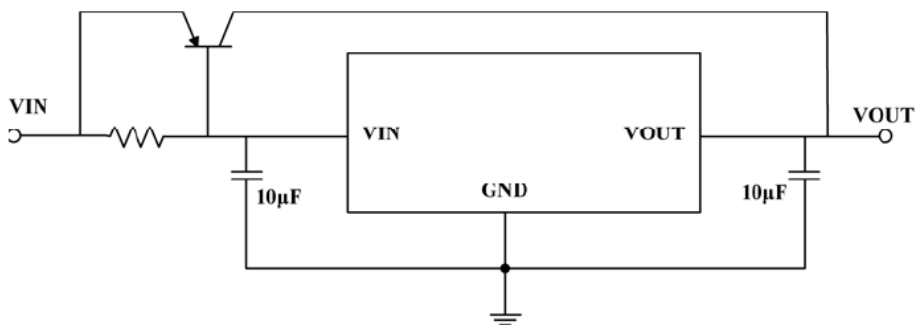
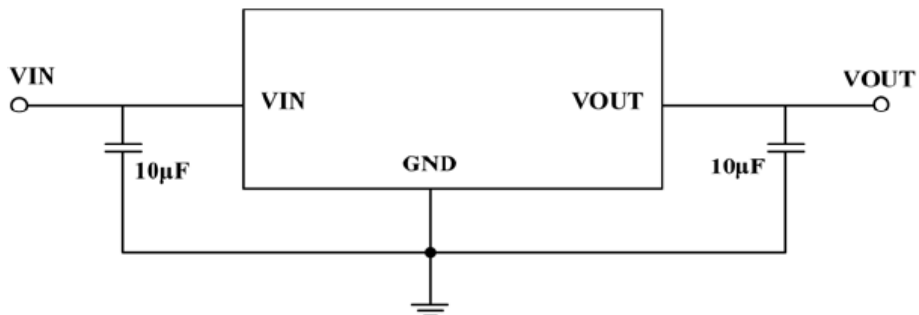

/ Typical Application Circuit

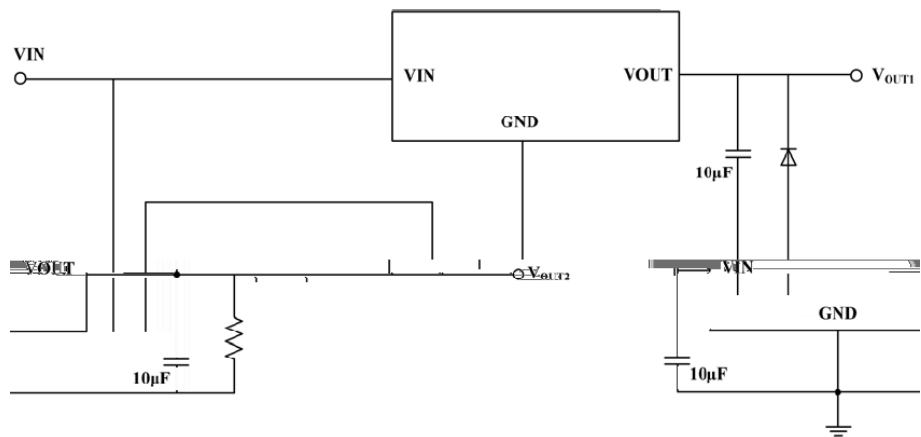
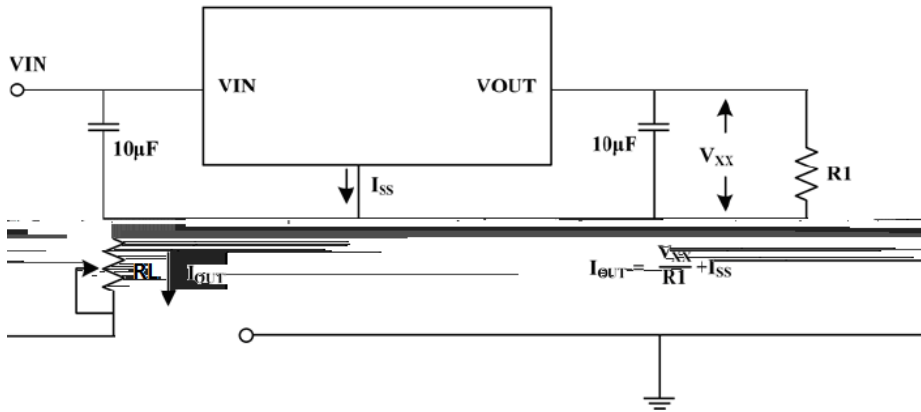
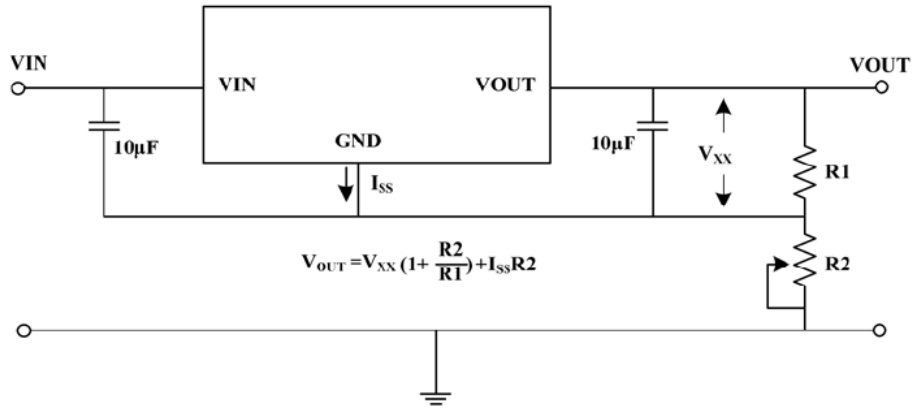

/ Marking Instructions

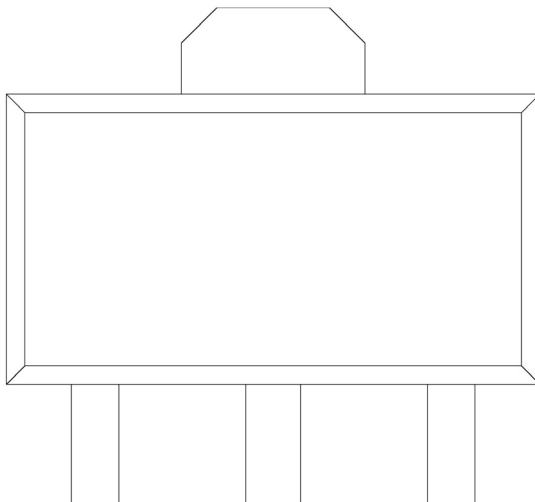

() / Temperature Profile for IR Reflow Soldering(Pb-Free)

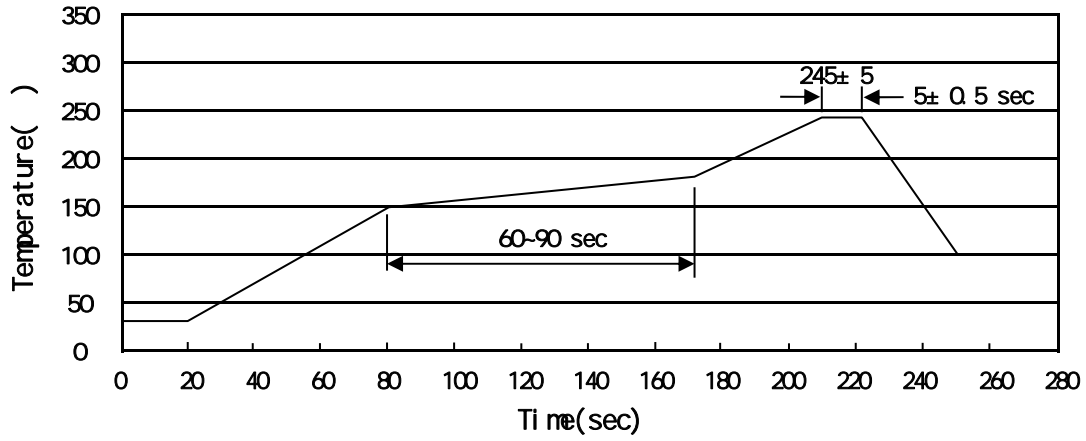

± ± ± ±

/ Resistance to Soldering Heat Test Conditions

± ± °C

/ Packaging SPEC.

						"		

/ Notices