

×

DC-DC

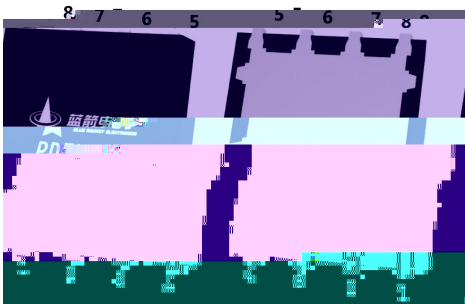

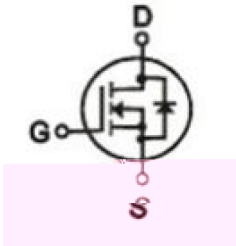

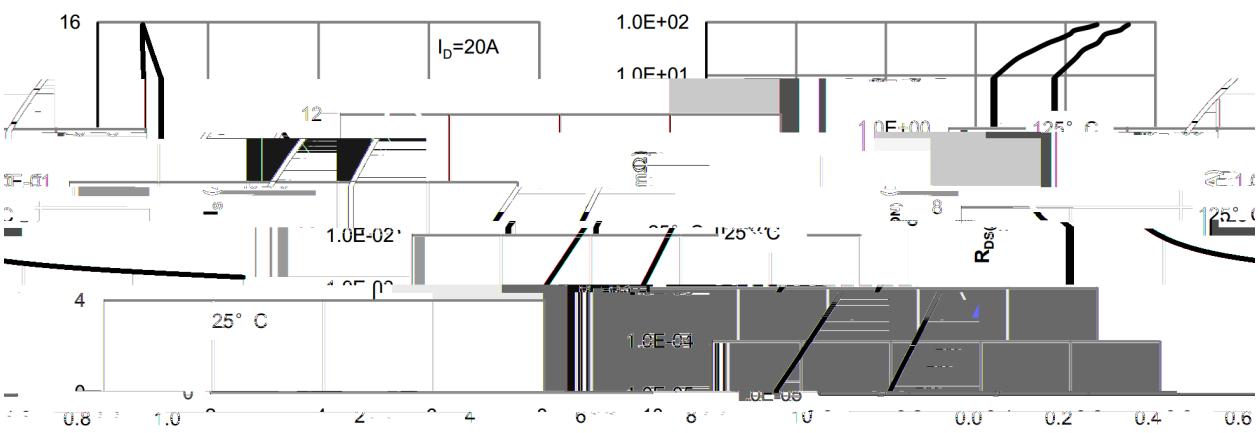
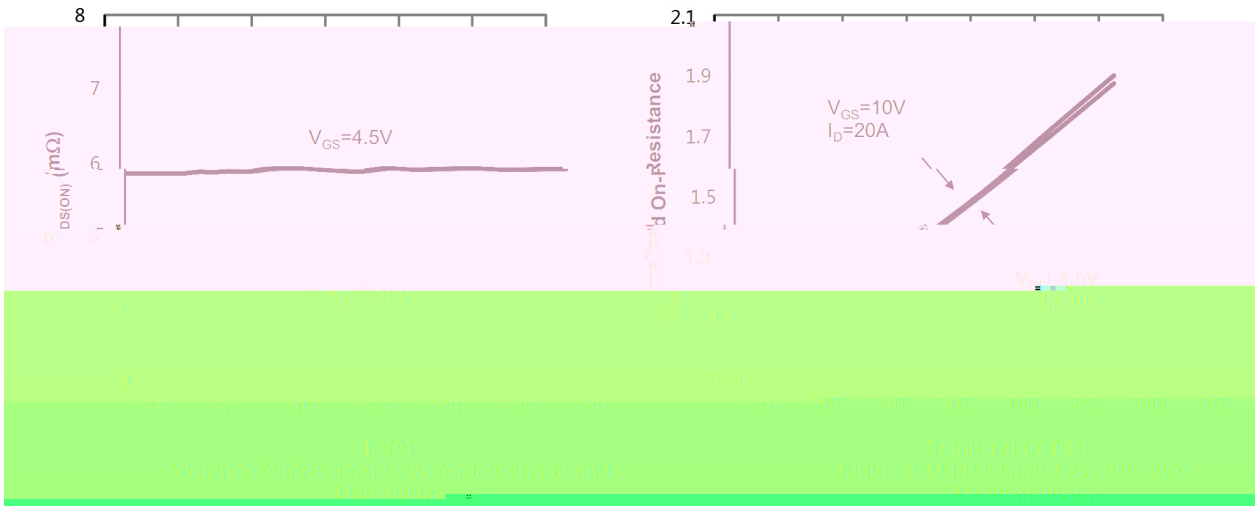
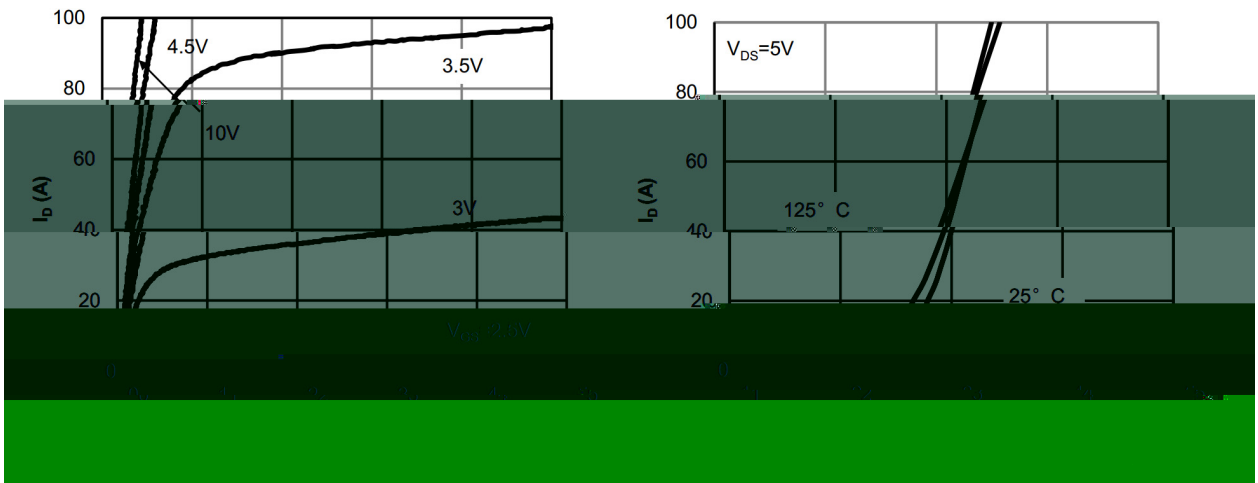

Figure 4: Drain Current vs. Gate-Source Voltage

Figure 5: On-Resistance vs. Gate-Source Voltage

Figure 6: Body-Diode Characteristics

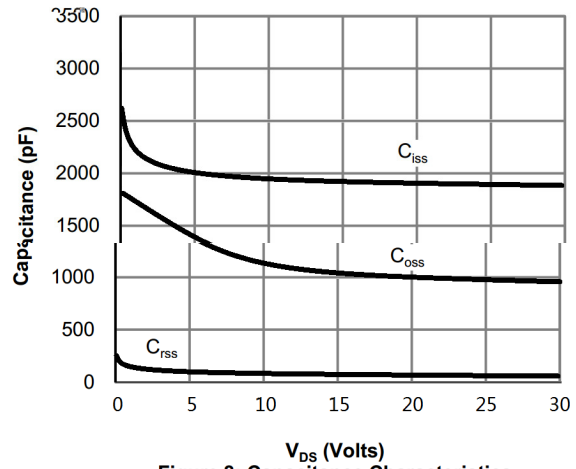
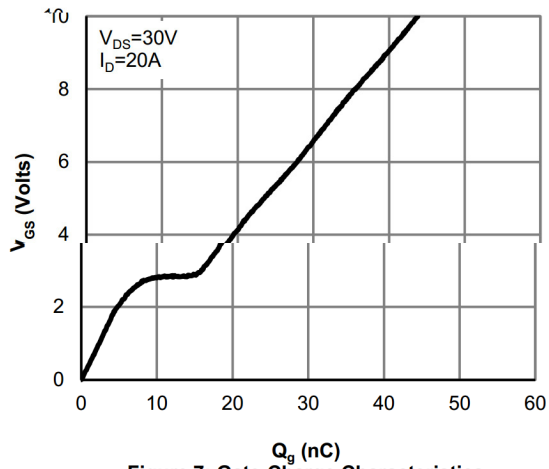
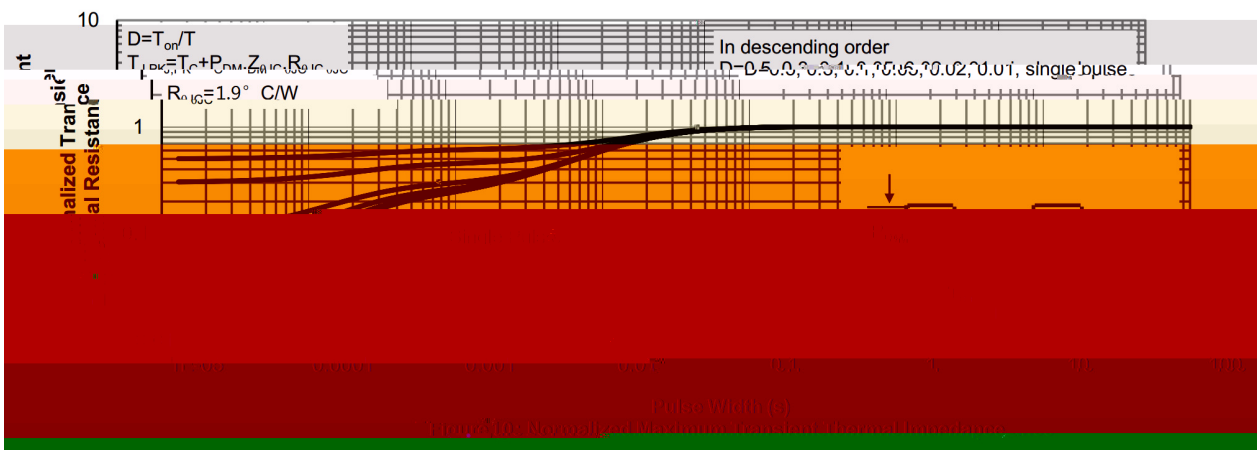
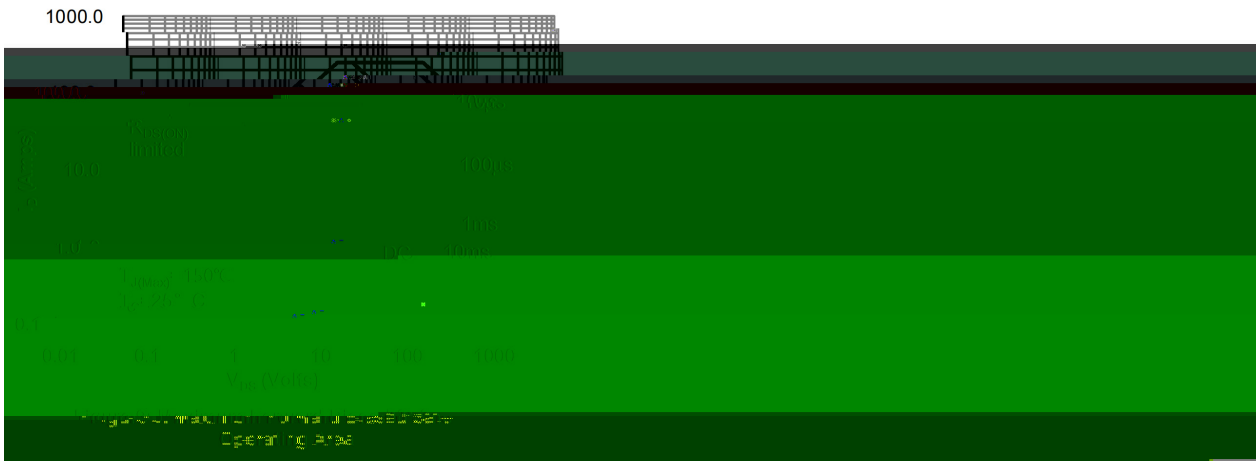
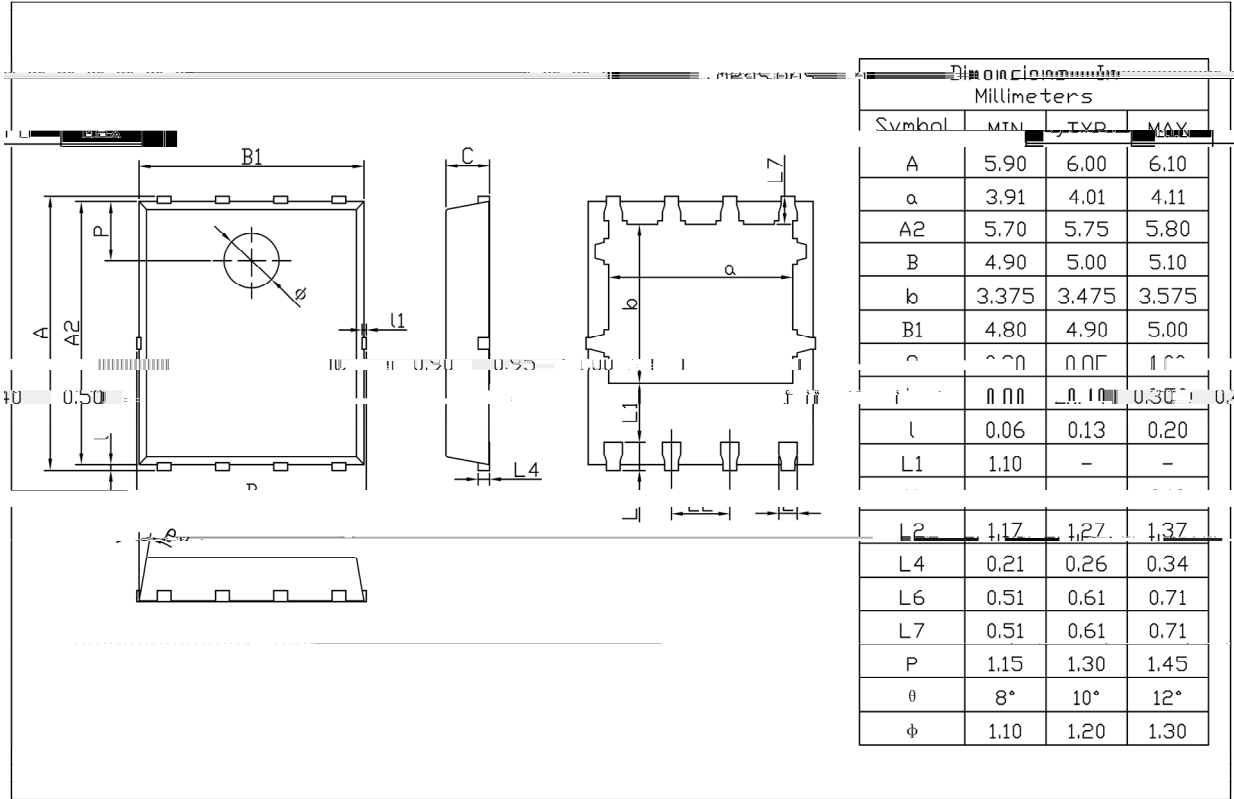

Figure 7: Gate Charge Characteristic Figure 8: Capacitance Characteristic



PDFN5 X6

Unit:mm



Rev.01 202209

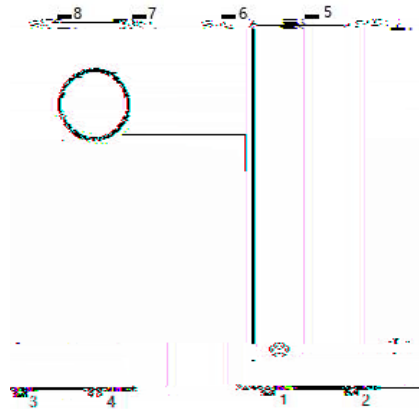

BR

Q
