

## / Descriptions

## / Features

$R_{DS(on)}$                        $C_{rss}$

## / Applications

DC/DC

## / Equivalent Circuit

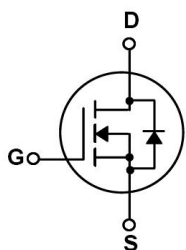

## / Pinning

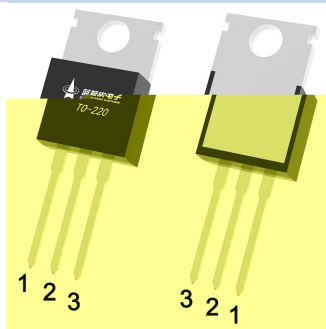

## / Marking



# BRCS120N06SRA

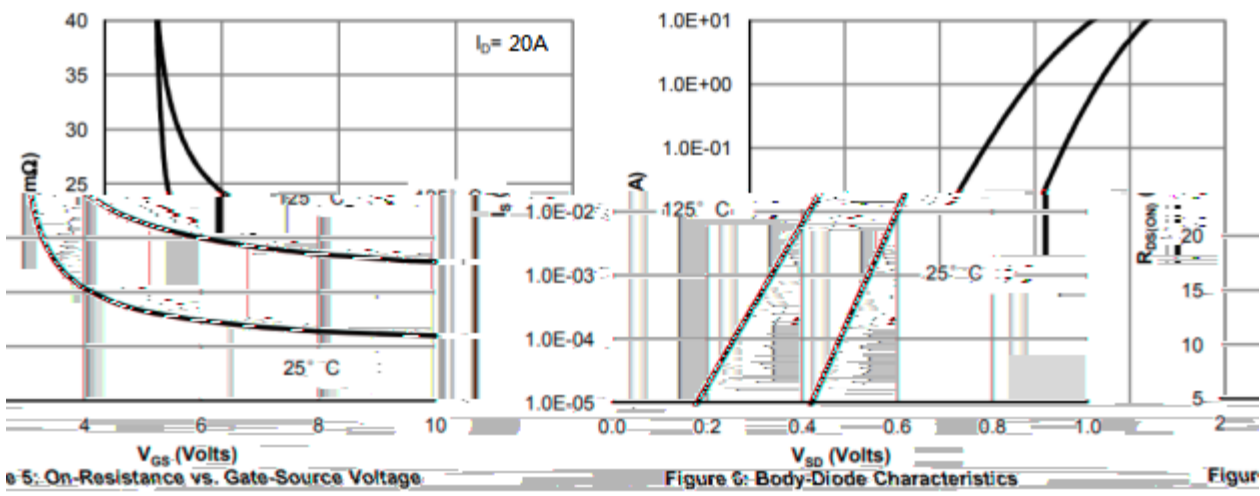
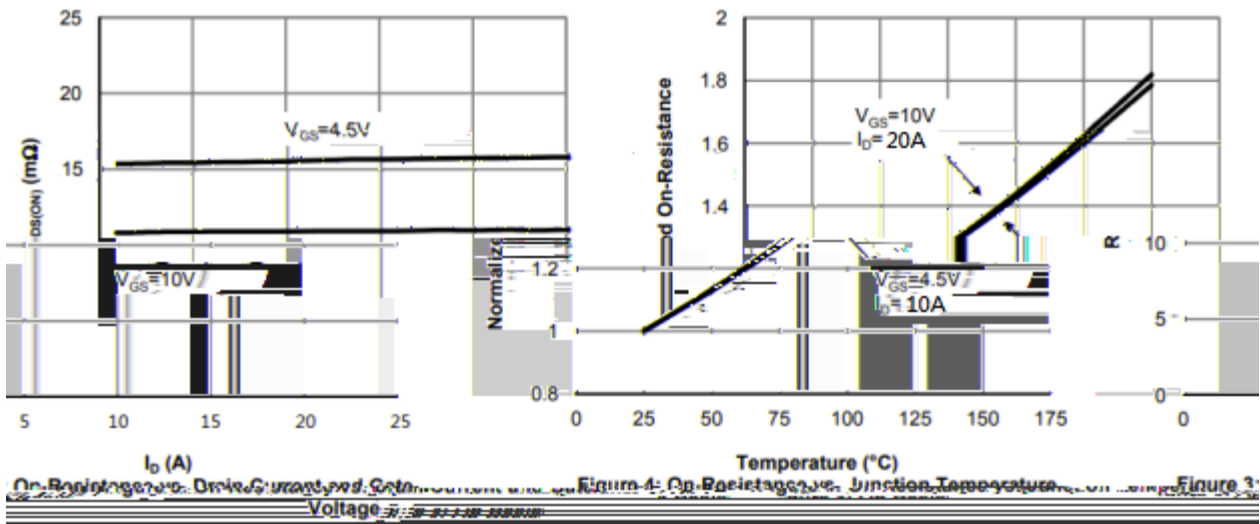
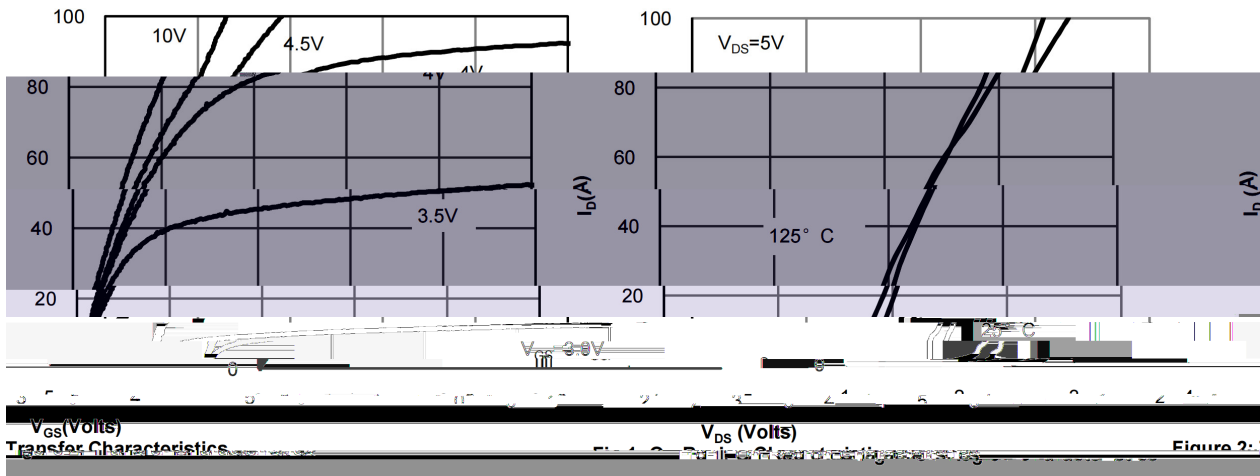

/ Electrical Characteristic Curve

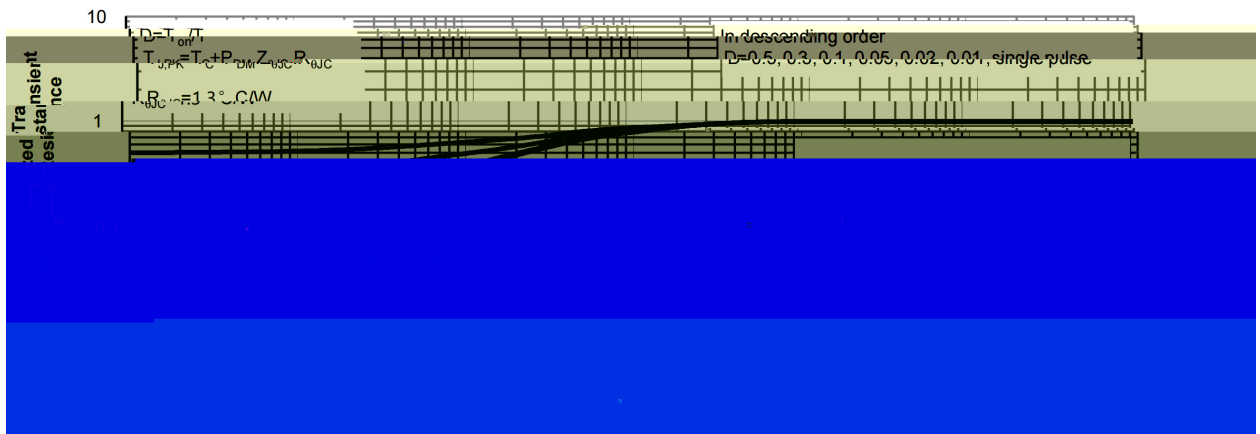
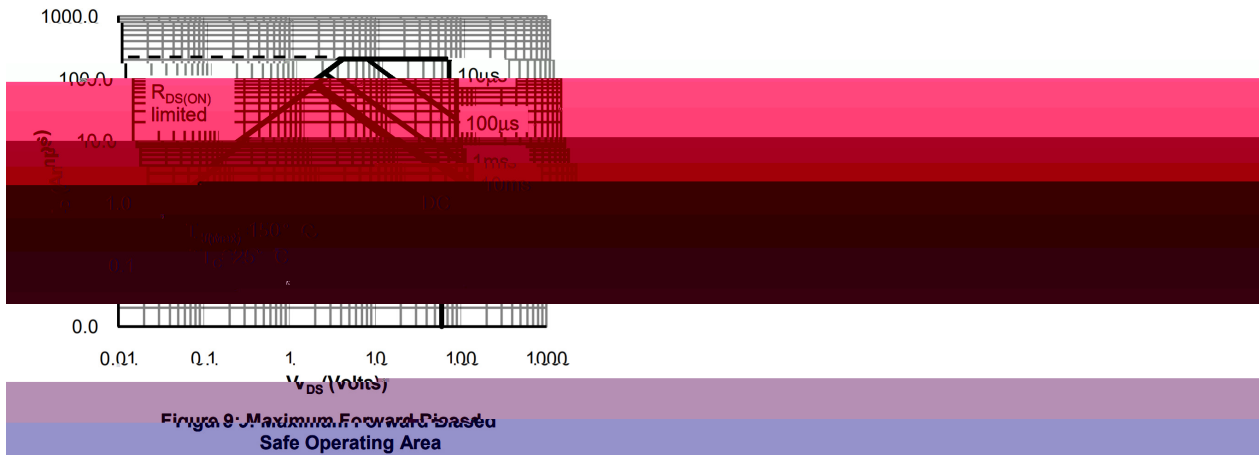
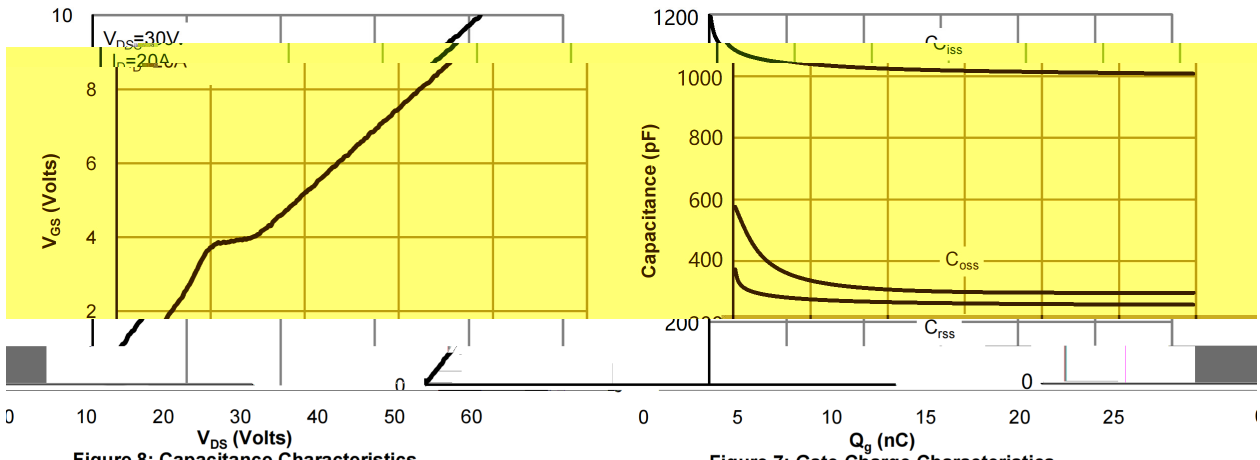

/ Electrical Characteristic Curve

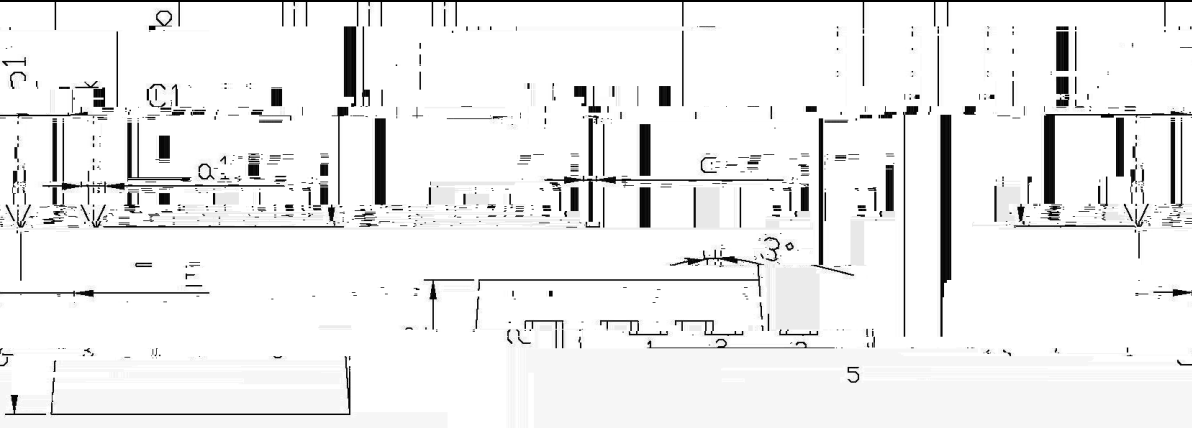
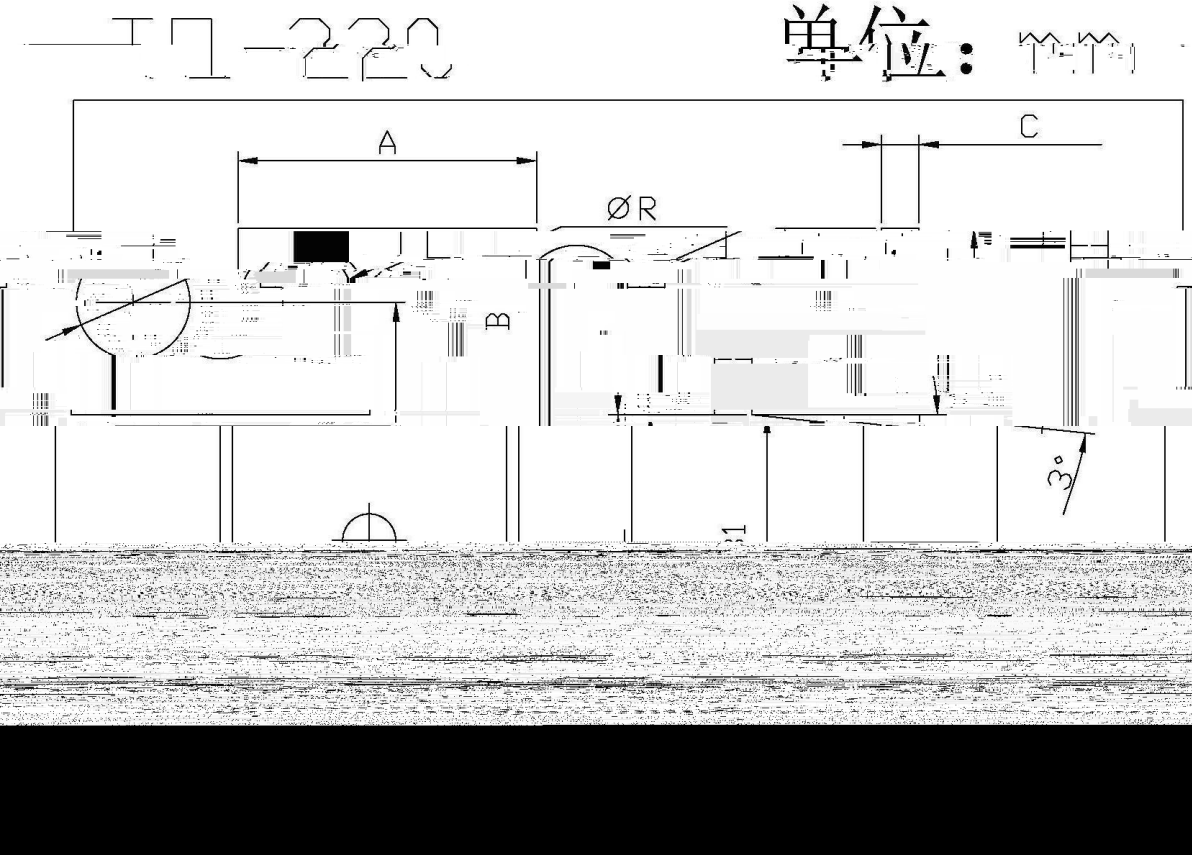

/ Package Dimensions



Symbol	Dimensions In Millimeters		Symbol	Dimensions In Millimeters	
	Min	Max		Min	Max
A	9.8	10.2	C	1.2	1.4
B	6.3	6.7	R	3.56	3.64

/ Marking Instructions

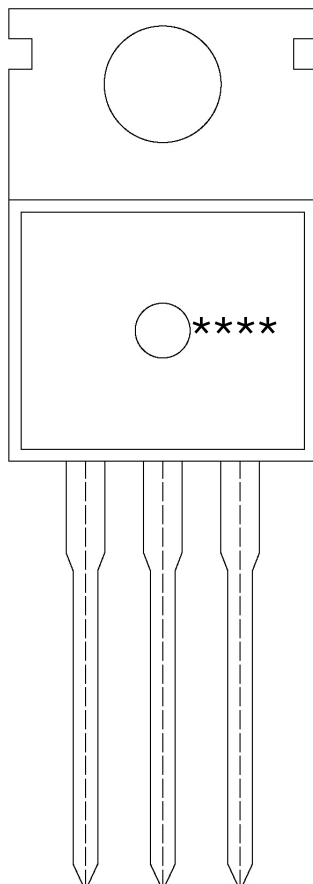

BR  
120N06S  
\*\*\*\*

( ) / Temperature Profile for Dip Soldering(Pb-Free)

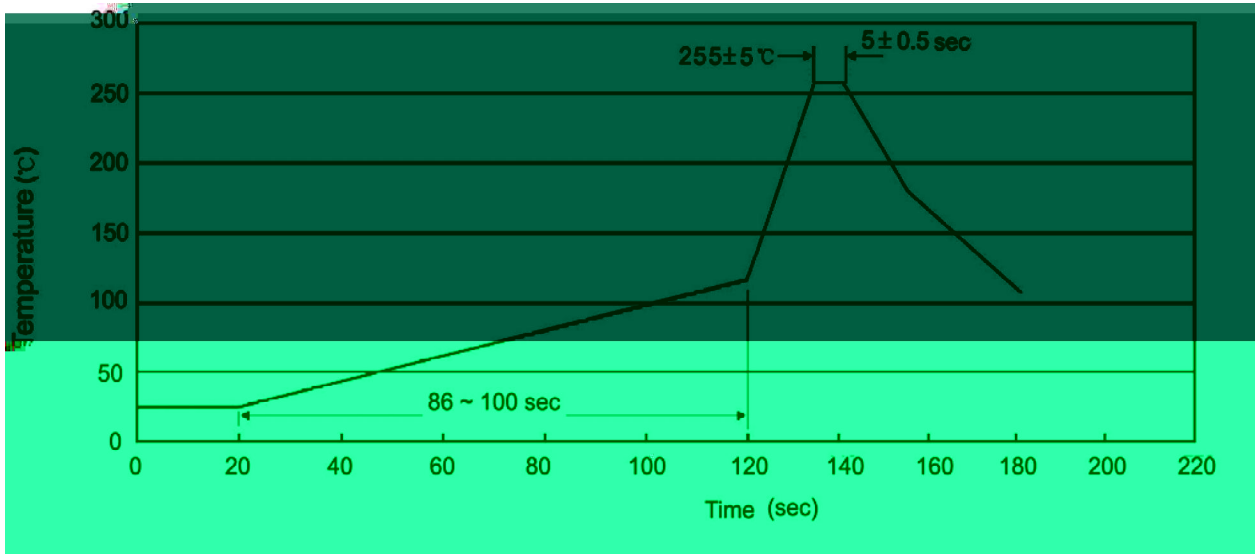

± ± ± ±

/ Resistance to Soldering Heat Test Conditions

± ±

/ Packaging SPEC.

封装形式	包装数量					包装尺寸 :		
	Units/Bag 只/袋	Bags/Inner Box 袋/盒	Units/Inner Box 只/盒	Inner Boxes/Outer Box 盒/箱	Units/Outer Box 只/箱	Bag 袋	Inner Box 盒	Outer Box 箱

封装形式	包装数量					包装尺寸 :		
	Units/Tube 只/套管	Tubes/Inner Box 套管/盒	Units/Inner Box 只/盒	Inner Boxes/Outer Box 盒/箱	Units/Outer Box 只/箱	Tube 套管	Inner Box 盒	Outer Box 箱

/ Notices