

**BRCS120P03ZC**



**DATA SHEET**

×

×





/ Electrical Characteristic Curve

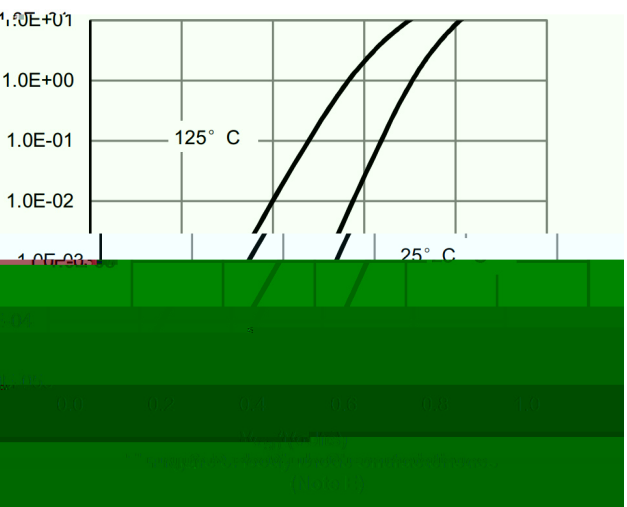
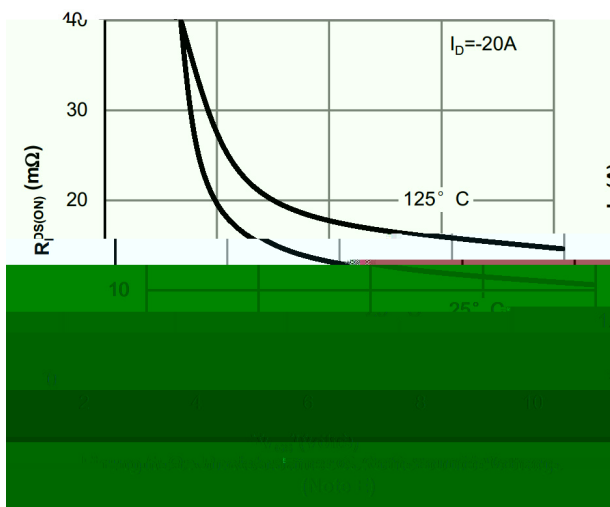
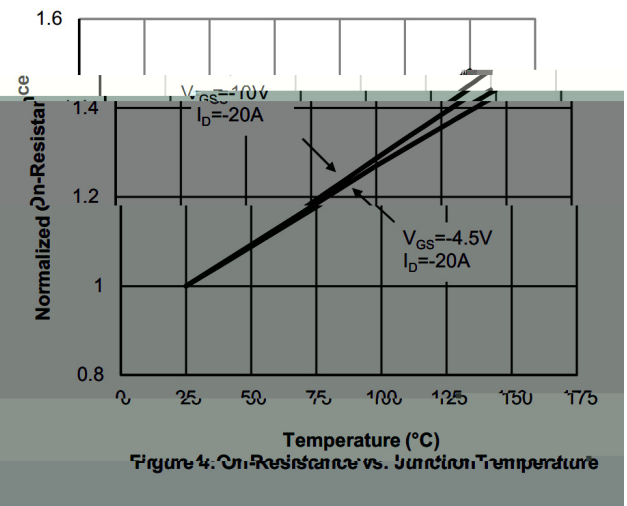
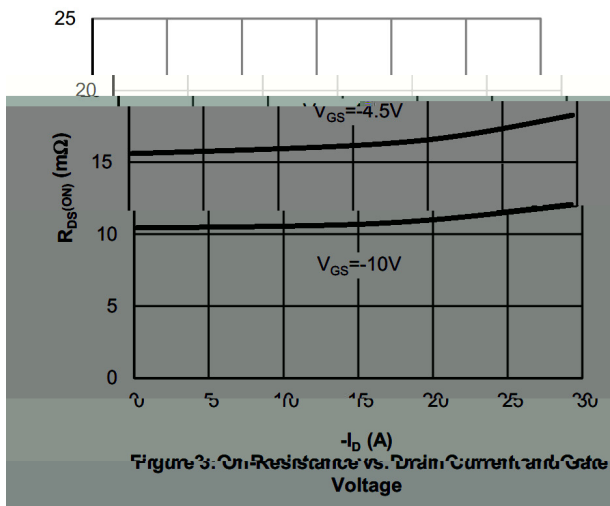
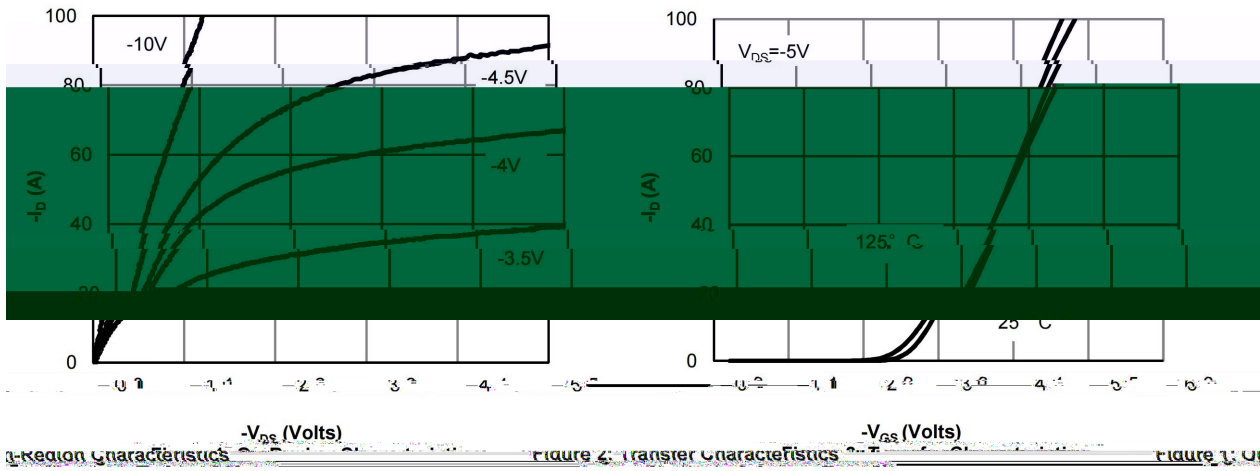

/ Electrical Characteristic Curve

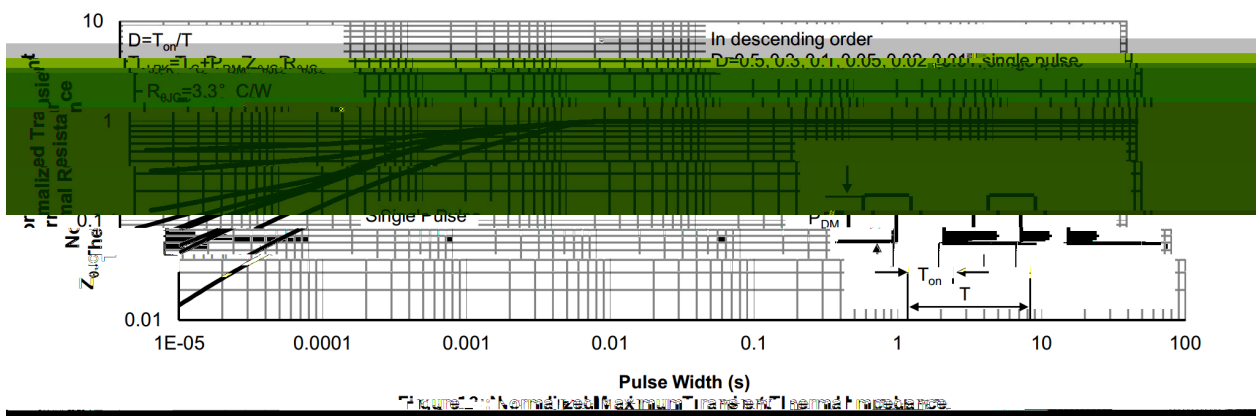
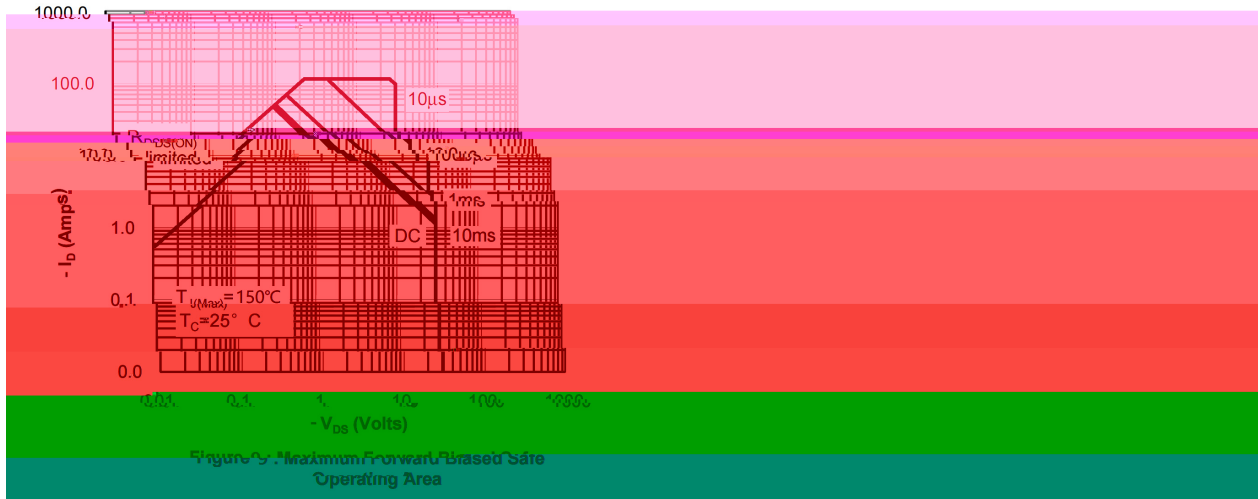
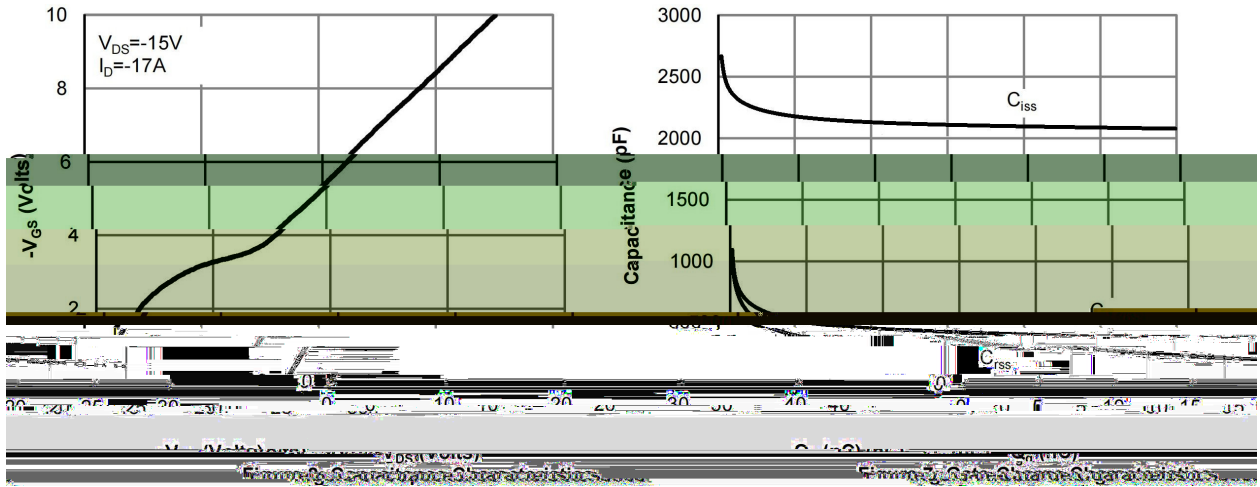

**/ Package Dimensions**

PDFN5 X6

Unit:mm

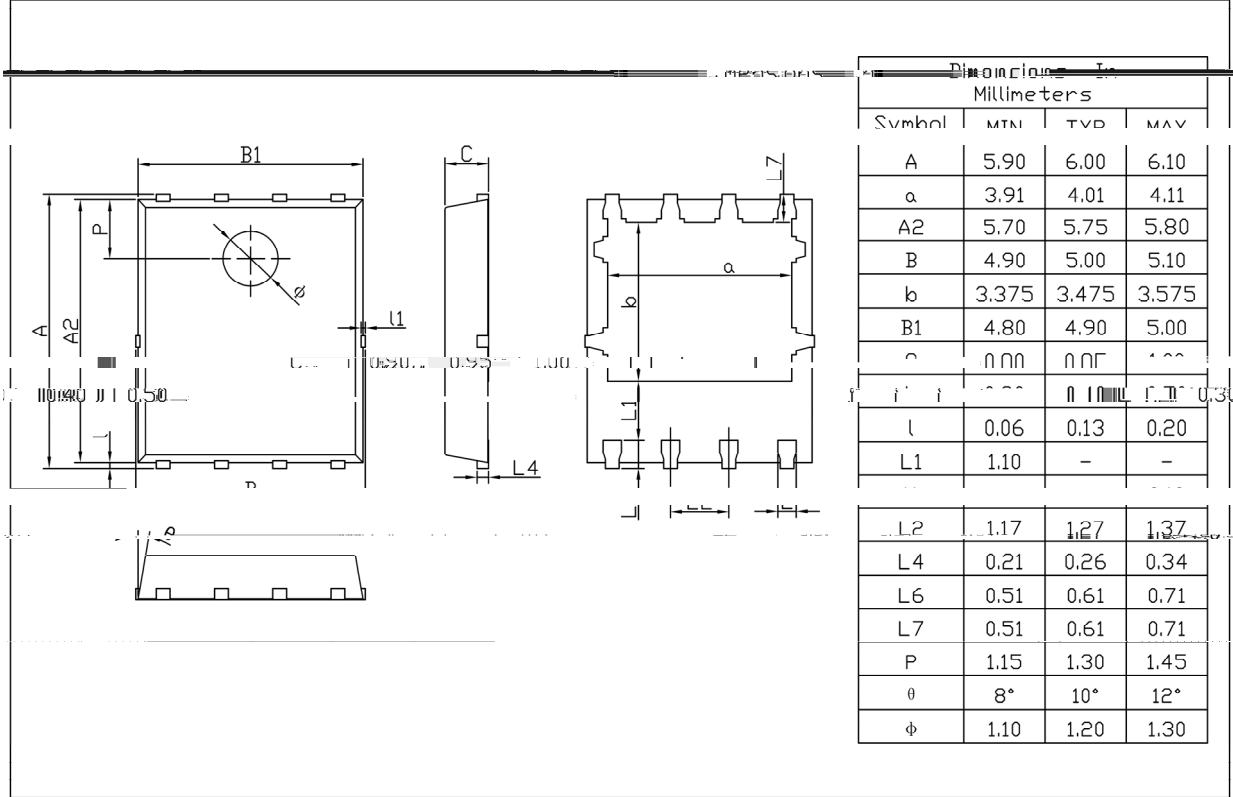

Rev.01 202209

/ Marking Instructions

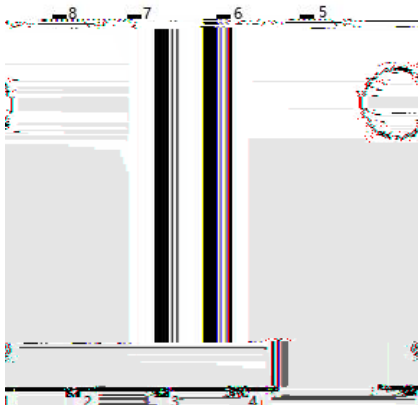

( ) / Temperature Profile for IR Reflow Soldering(Pb-Free)

± ± ± ±

/ Resistance to Soldering Heat Test Conditions

± ±

/ Packaging SPEC.

Units/Reel /	Reels/Inner Box /	Units/Inner Box /	Inner Boxes/Outer Box /
-----------------	----------------------	----------------------	----------------------------