

/ Descriptions

P

/ Features

±

/ Applications

DC/DC

/ Equivalent Circuit

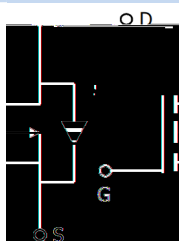

/ Pinning

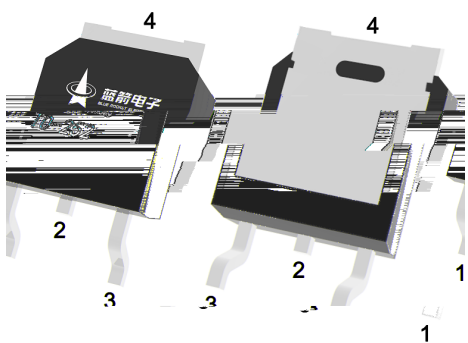

/ Marking

			°C
			°C
			°C
			°C

		μ				
		μ				

/ Electrical Characteristics(Ta=25 )

/ Electrical Characteristic Curve

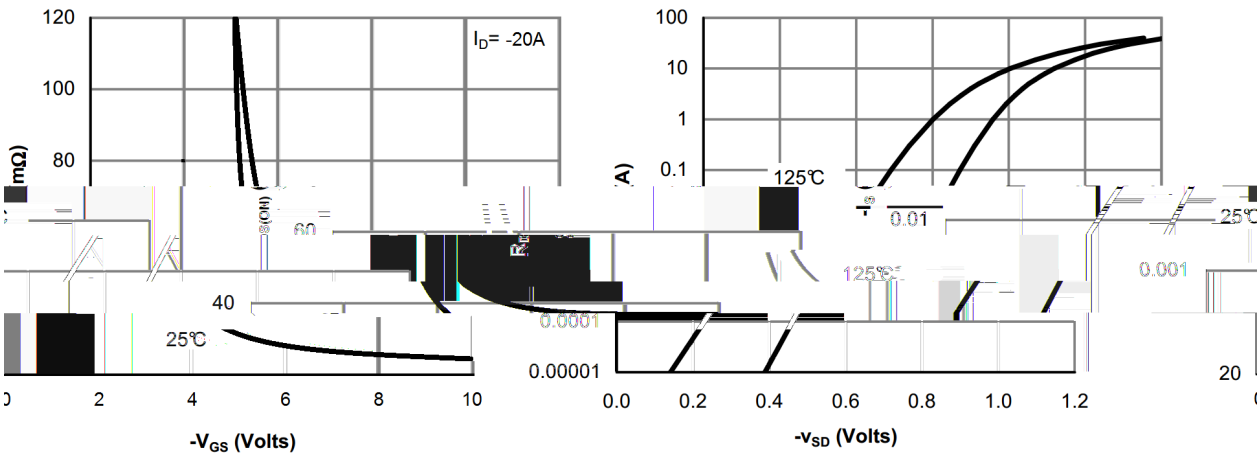
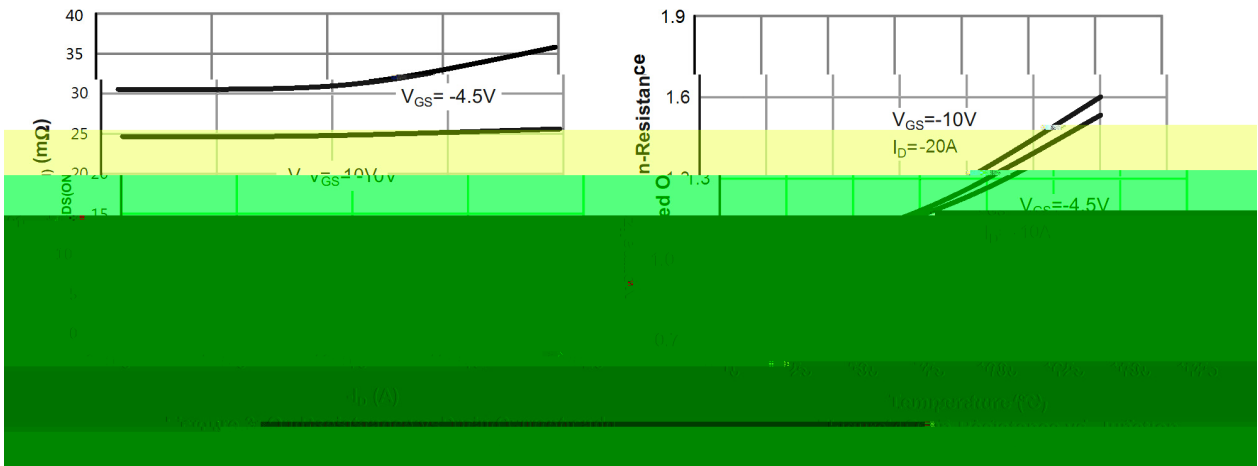
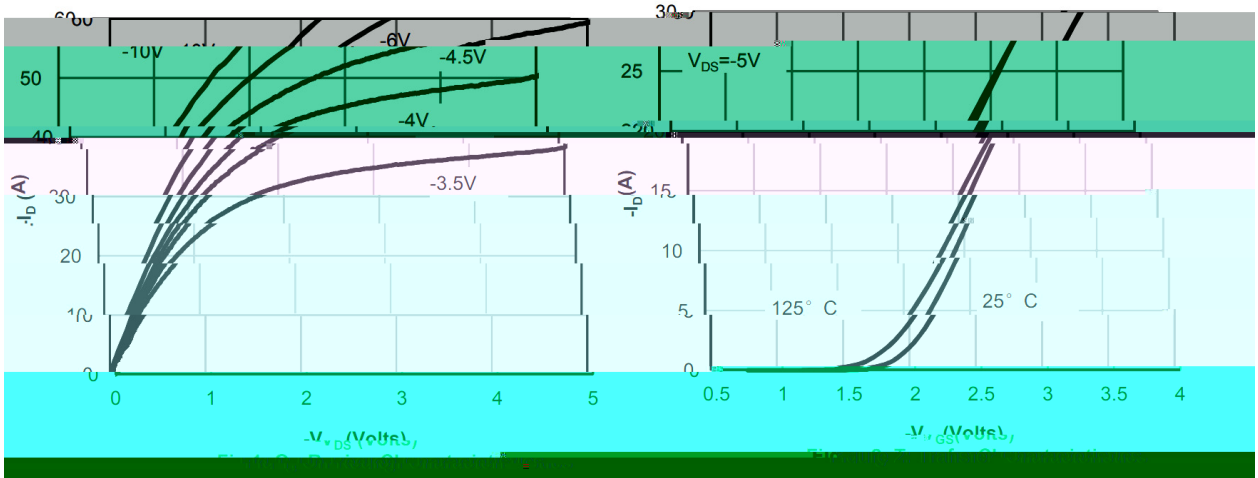
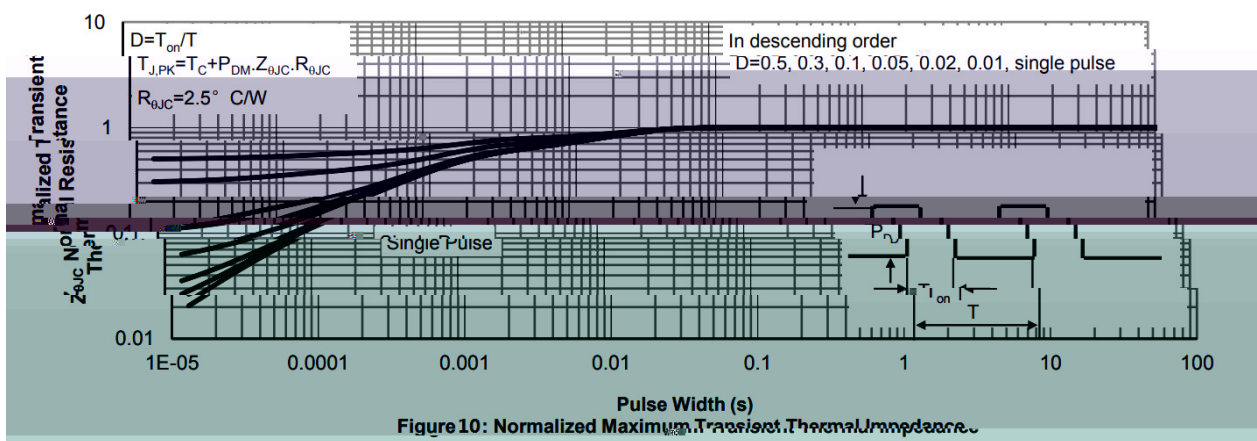
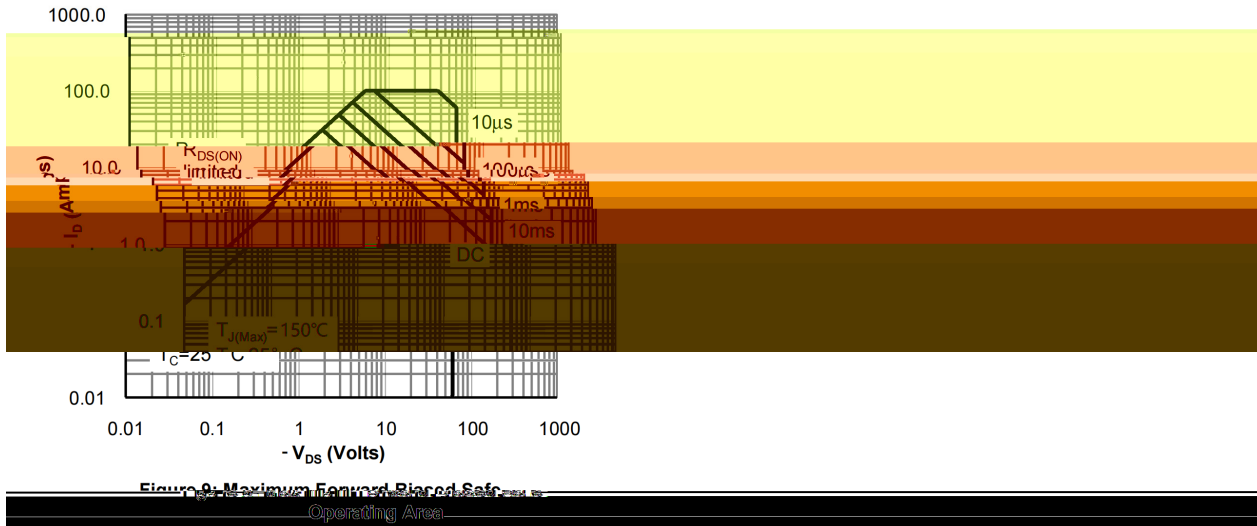
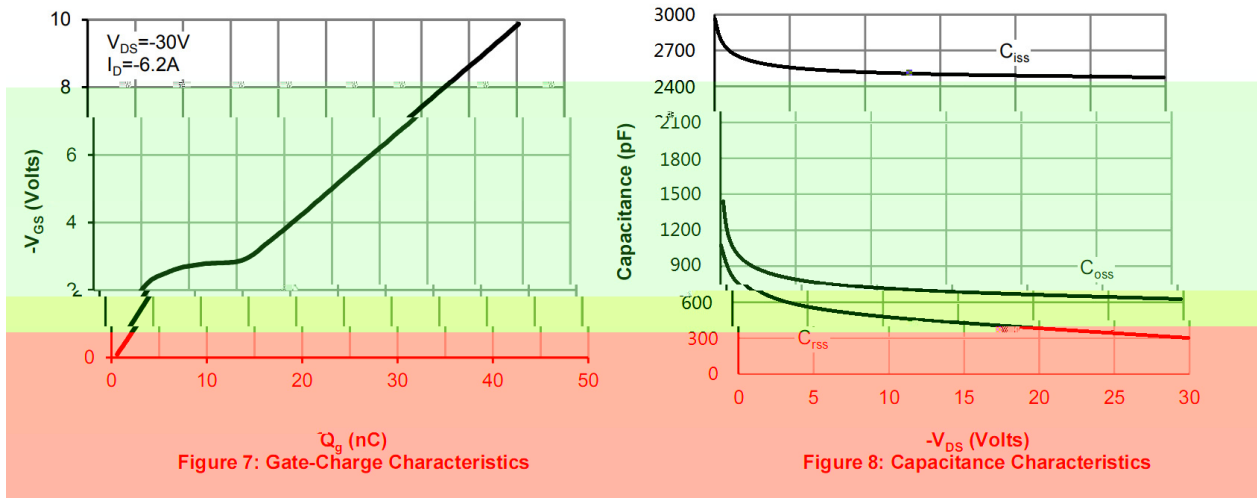

Figure 5: On-Resistance vs. Gate-Source Voltage

Figure 6: Body-Diode Characteristics

/ Electrical Characteristic Curve



/ Package Dimensions

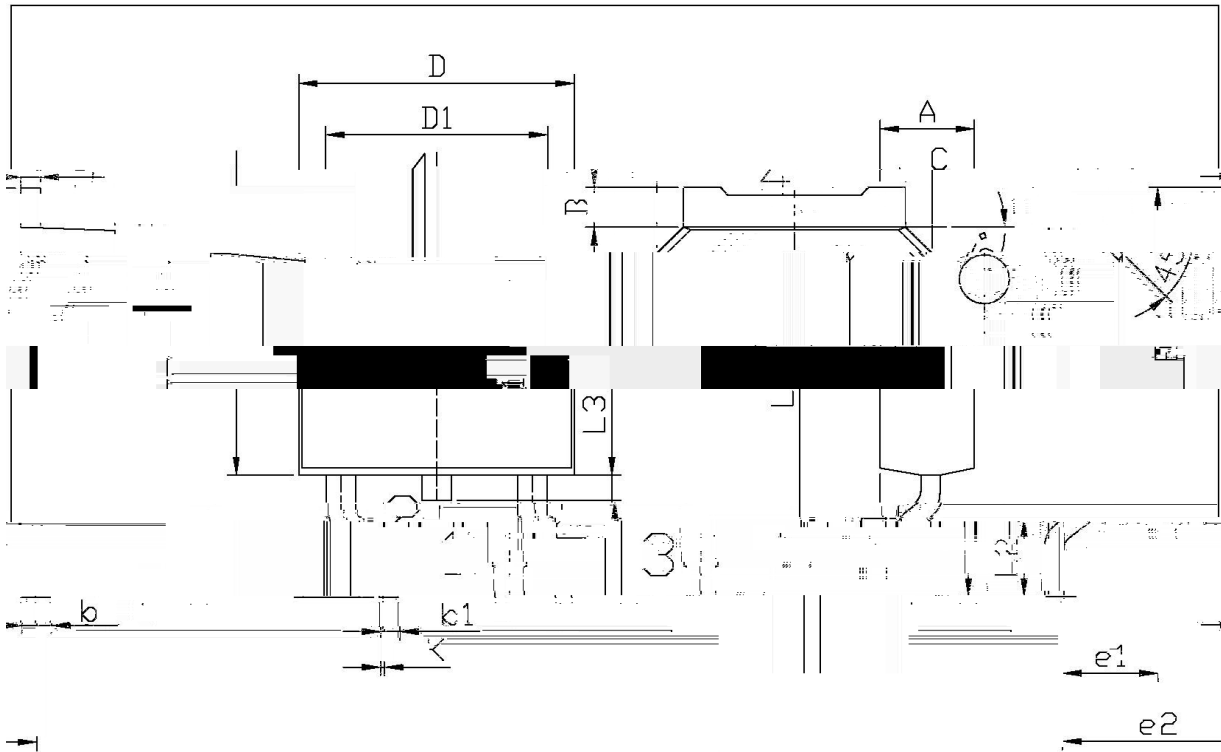

单位: mm

Symbol	Dimensions In Millimeters		Symbol	Dimensions In Millimeters	
	Min.	Max.		Min.	Max.
E	5.95	6.25	A	2.20	2.40
e1	2.24	2.34	B	0.95	1.25
b	9.85	10.35	L1	0.45	0.55
L3	0.60	0.90	D	6.45	6.75
K	0.00	0.10	JR	0.10	0.50

252

T0-2

**/ Marking Instructions**

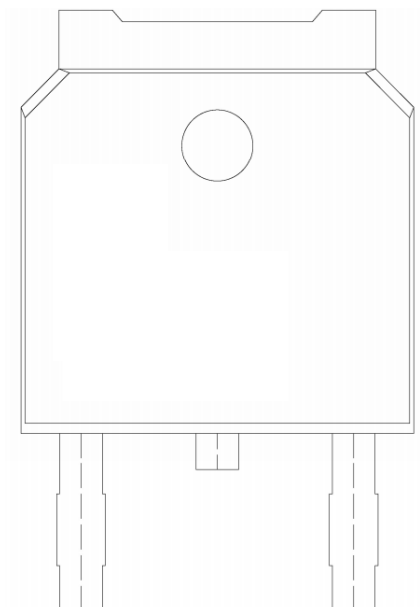

350P06

\*\*\*\*

( ) / Temperature Profile for IR Reflow Soldering(Pb-Free)

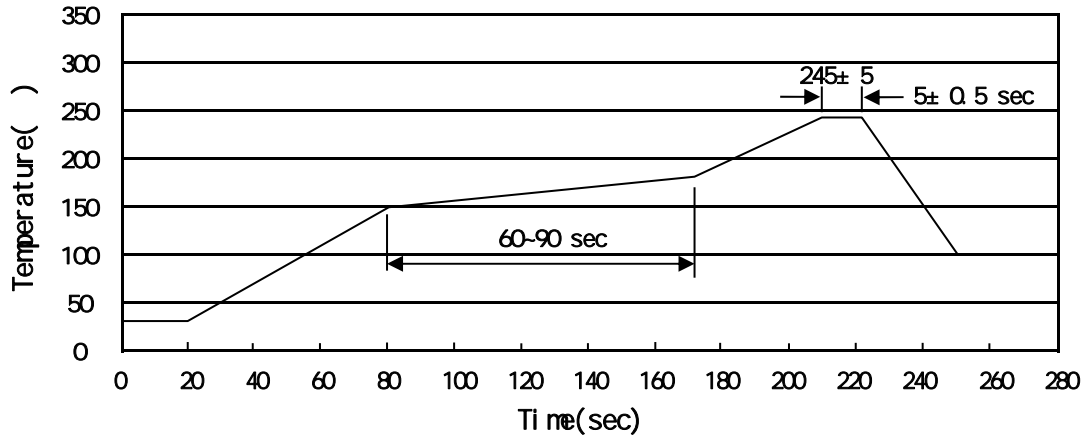

± ± ± ±

/ Resistance to Soldering Heat Test Conditions

± ± °C

/ Packaging SPEC.

封装形式	包装数量					包装尺寸 :		
	Units/Reel 只/卷盘	Reels/Inner Box 卷盘/盒	Units/Inner Box 只/盒	Inner Boxes/Outer Box 盒/箱	Units/Outer Box 只/箱	Reel	Inner Box 盒	Outer Box 箱

封装形式	包装数量					包装尺寸 :		
	Units/Tube 只/套管	Tubes/Inner Box 套管/盒	Units/Inner Box 只/盒	Inner Boxes/Outer Box 盒/箱	Units/Outer Box 只/箱	Tube 套管	Inner Box 盒	Outer Box 箱

/ Notices