

# BRCS9N20YU

Rev.A Sep.-2023

## / Descriptions

DFN8×8-4L N

Dual N-CHANNEL MOSFET in a DFN8×8-4L Plastic Package.

## / Features

$V_{DS}(V)=200V$   $I_D=9A$

$R_{DS(ON)}@10V<0.45\Omega$ (Typ. 0.4 )

$R_{DS(ON)}@6V<0.6\Omega$ (Typ. 0.5 $\Omega$ )

HF Product.

## / Applications

LED

Used in high-frequency switching power supply, electronic ballast, LED power supply and high-speed air duct.

## / Equivalent Circuit

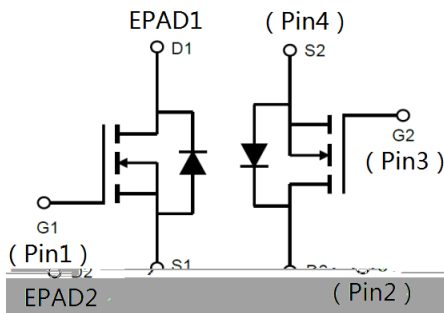

## / Pinning

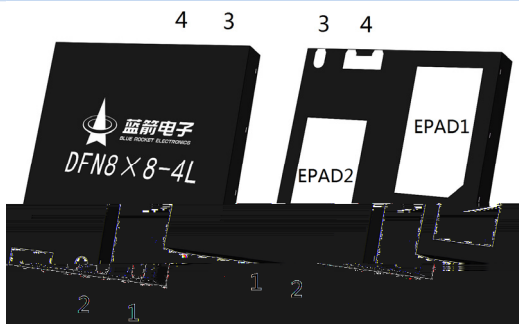

PIN 1	G1	PIN 2	S1	EPAD1	D1
PIN 3	G2	PIN 4	S2	EPAD2	D2

## / Marking

See Marking Instructions.

## / Absolute Maximum Ratings(Ta=25 )

Parameter	Symbol	Rating	Unit
Drain-Source Voltage	$V_{DS}$	200	V
Drain Current	$I_D(T_C=25)$	9	A
Drain Current - Pulsed	$I_{DM}$	28.6	A
Gate-Source Voltage	$V_{GS}$	$\pm 20$	V
Avalanche Current	$I_{AR}$	5	A
Single Pulsed Avalanche Energy	$E_{AS}$	166	mJ
Power Dissipation (Tc=25 )	$P_D$	70	W
Operating and Storage Temperature Range	$T_J, T_{STG}$	-55 to 150	
Thermal resistance,Junction to Case	$R_{JC}$	1.79	/W

## / Electrical Characteristics(Ta=25 )

Parameter	Symbol	Test Conditions	Min	Typ	Max	Unit
Drain-Source Breakdown Voltage	$BV_{DSS}$	$V_{GS}=0V$ $I_D=250\mu A$	200	230		V
Zero Gate Voltage Drain Current	$I_{DSS}$	$V_{DS}=200V$ $V_{GS}=0V$			1	$\mu A$
Gate-Body Leakage Current Forward	$I_{GSS}$	$V_{GS}=\pm 20V$ $V_{DS}=0V$			$\pm 0.1$	$\mu A$
Gate Threshold Voltage	$V_{GS(th)}$	$V_{DS}=V_{GS}$ $I_D=250\mu A$	2	3	4	V
Static Drain-Source On-Resistance	$R_{DS(on)}$	$V_{GS}=10V$ $I_D=4.5A$		0.4	0.45	$\Omega$
	$R_{DS(on)}$	$V_{GS}=6V$ $I_D=2.5A$		0.5	0.6	$\Omega$
Input Capacitance	$C_{iss}$	$V_{DS}=25V$ $V_{GS}=0V$ $f=1.0MHz$		630		pF
Output Capacitance	$C_{oss}$			270		pF
Reverse Transfer Capacitance	$C_{rss}$			50		pF
Total Gate Charge	$Q_G$	$V_{DS}=100V,$ $I_D=9.0A,$ $V_{GS}=10V$		26		nC
Gate-Source Charge	$Q_{GS}$			11.2		
Gate-Drain Charge	$Q_{GD}$			9.5		

## / Electrical Characteristics(Ta=25 )

Parameter	Symbol	Test Conditions	Min	Typ	Max	Unit
Turn-On Delay Time	$t_{d(on)}$	$V_{DS}=100V$ $I_D=9.0A$ $R_G=25\Omega$		15		ns
Turn-On Rise Time	$t_r$			33		
Turn-Off Delay Time	$t_{d(off)}$			40		
Turn-Off Fall Time	$t_f$			30		
Drain-Source Diode Forward Voltage	$V_{SD}$	$V_{GS} = 0 V,$ $I_S = 9.0A$			1.4	V
Reverse Recovery Time	$t_{rr}$	$V_{GS} = 0V,$ $I_S = 9.0A,$ $dI_F/dt = 100 A/\mu s$		455		nS
Reverse Recovery Charge	$Q_{rr}$			3.5		nC

**/ Electrical Characteristic Curve**

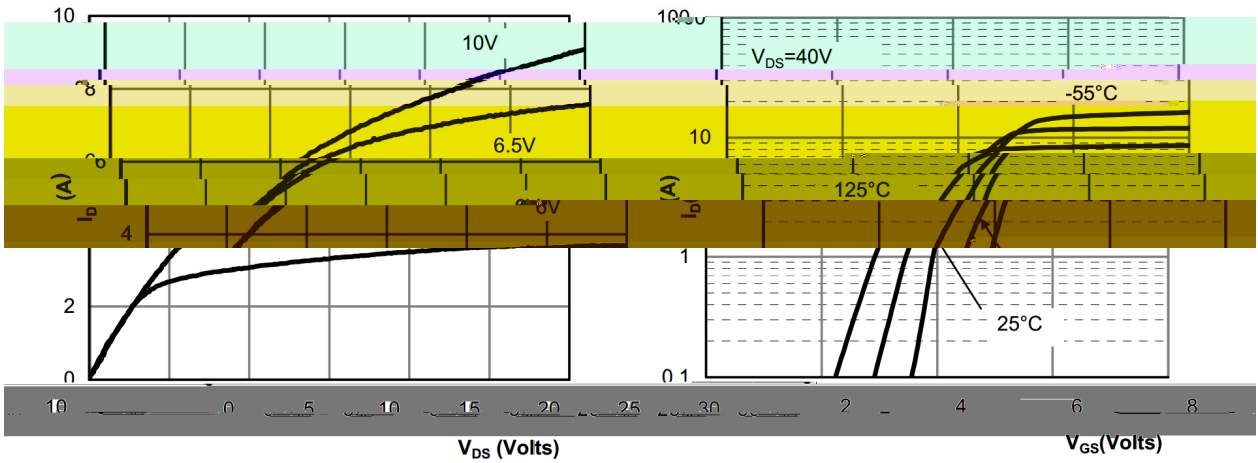

**Fig 1: On-Region Characteristics** **Figure 2: Transfer Characteristics**

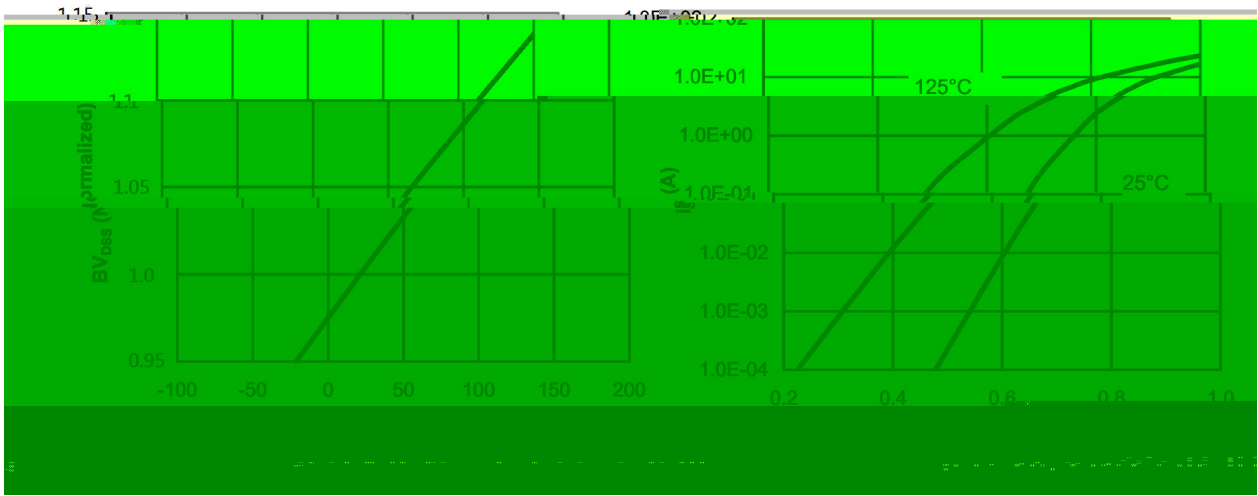
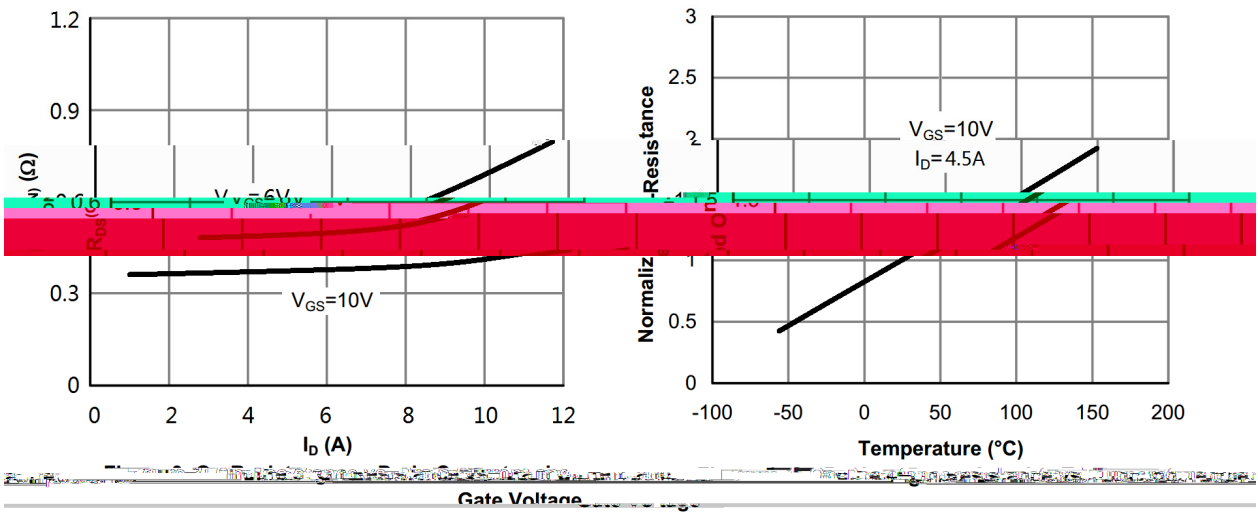

/ Electrical Characteristic Curve

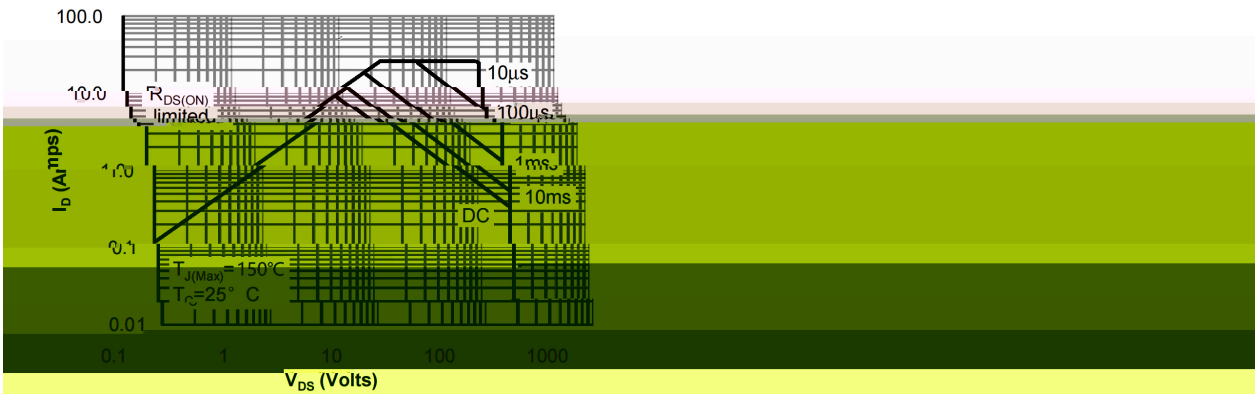
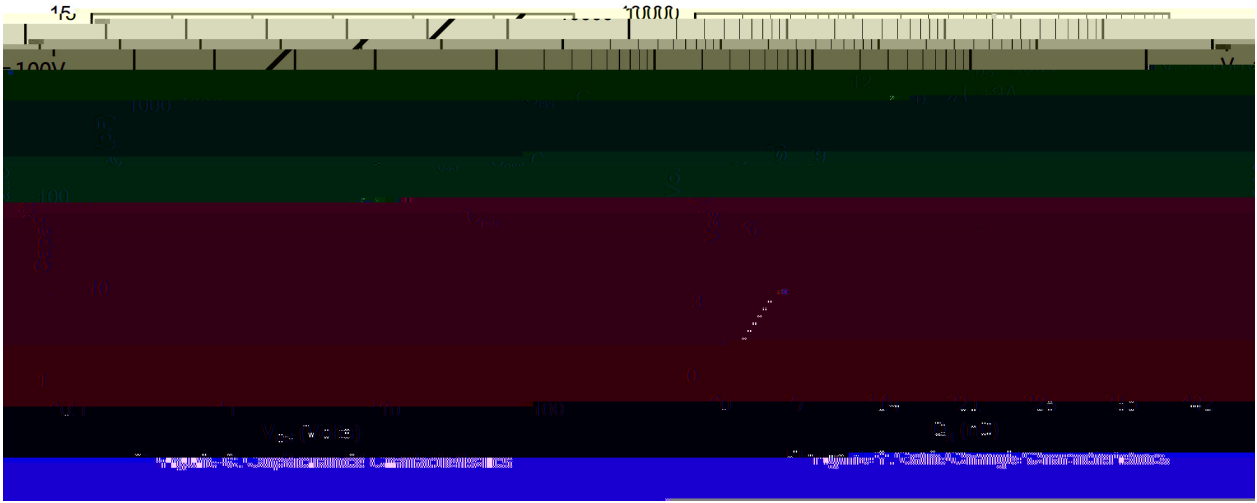

Figure 9: Maximum Forward biased Safe Operating Area

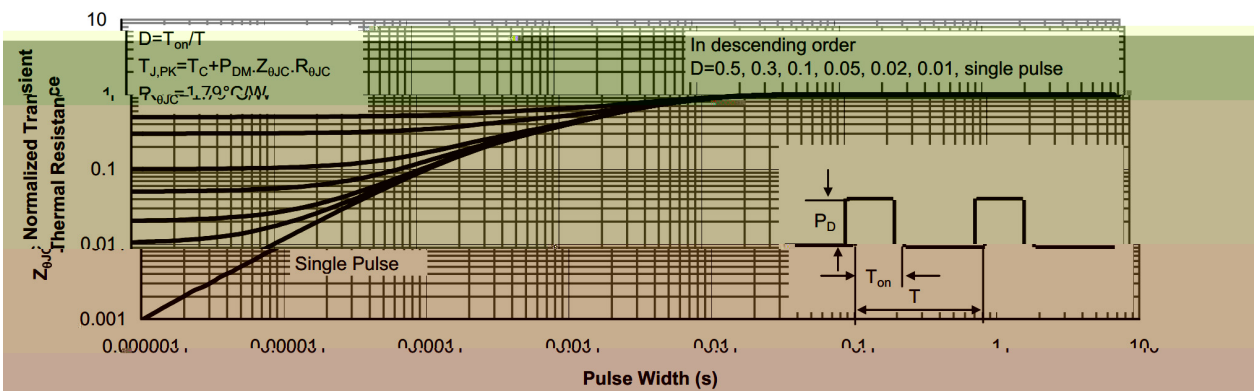
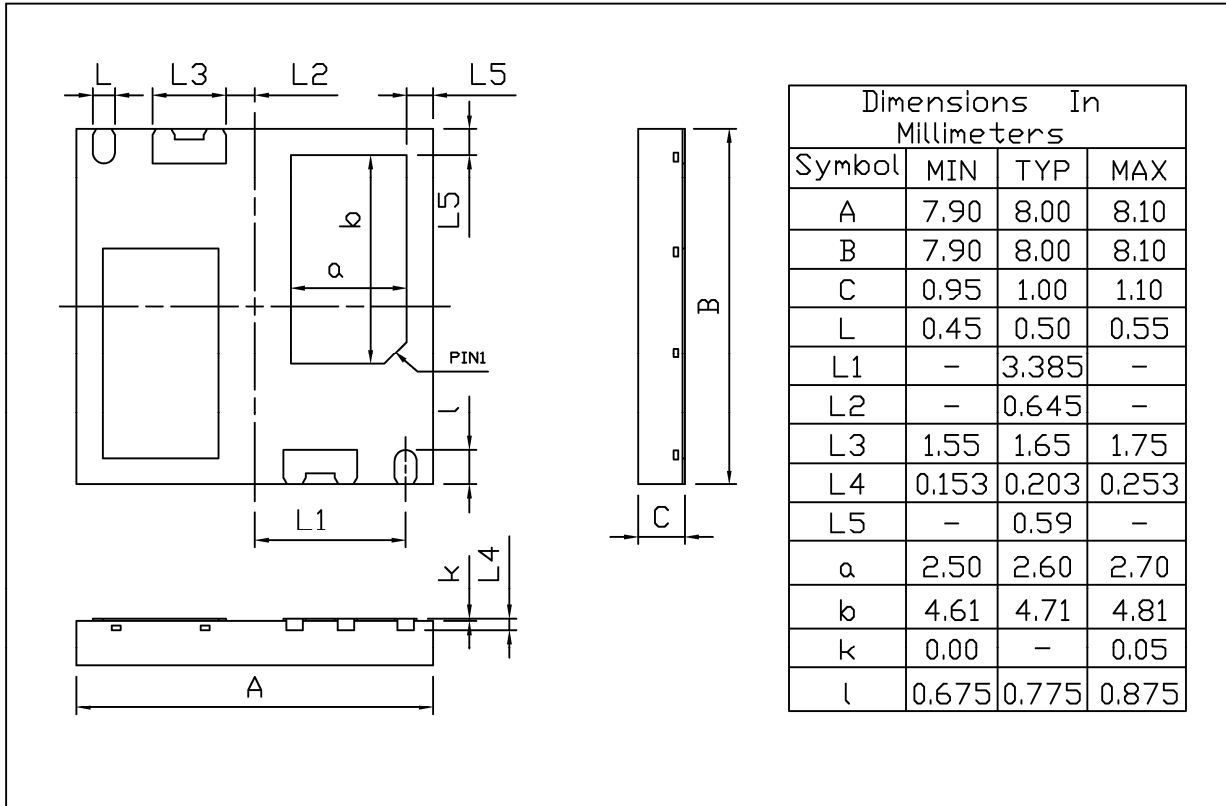

Figure 10: Normalized Maximum Transient Thermal Impedance

**/ Package Dimensions**

DFN8X8-4L

Unit:mm



Rev.00 202307

**/ Marking Instructions**

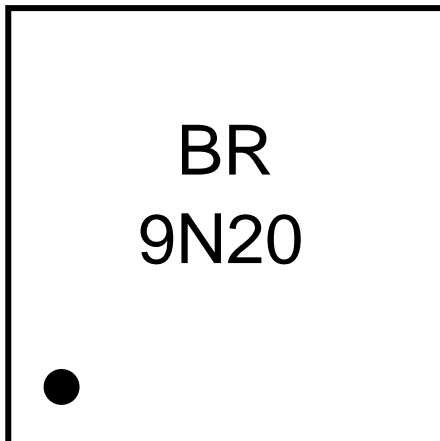

BR

9N20

\*\*\*\*

Note:

BR: Company Code

9N20: Product Type Code

\*\*\*\*: Lot No. Code, code change with Lot No

