

**BRFL10N65S**

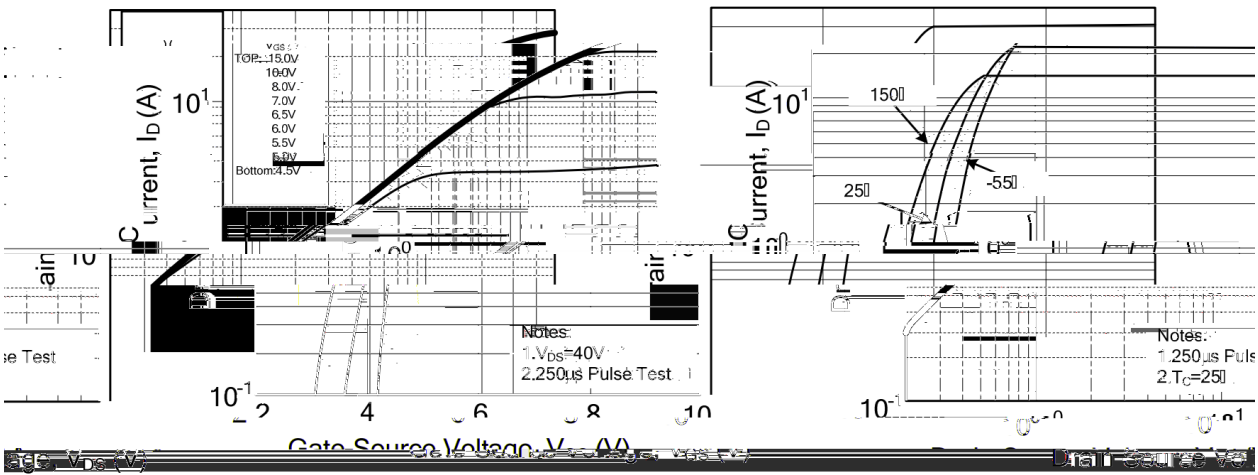

/ Electrical Characteristic Curve

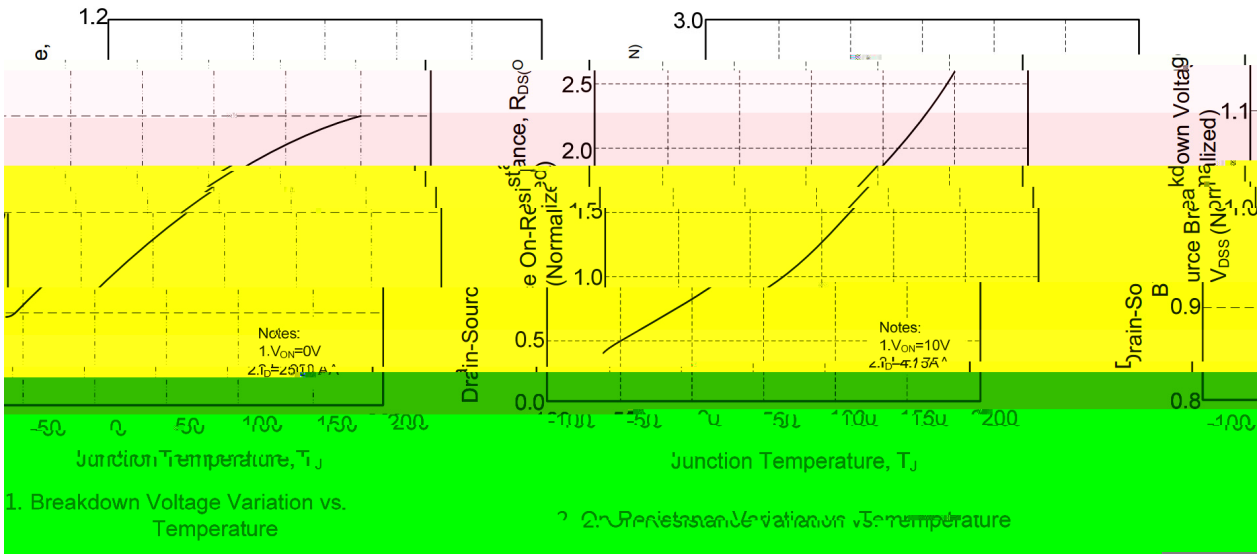

Transfer Characteristics

4. Transfer Characteristics

3. On-Region Characteristics

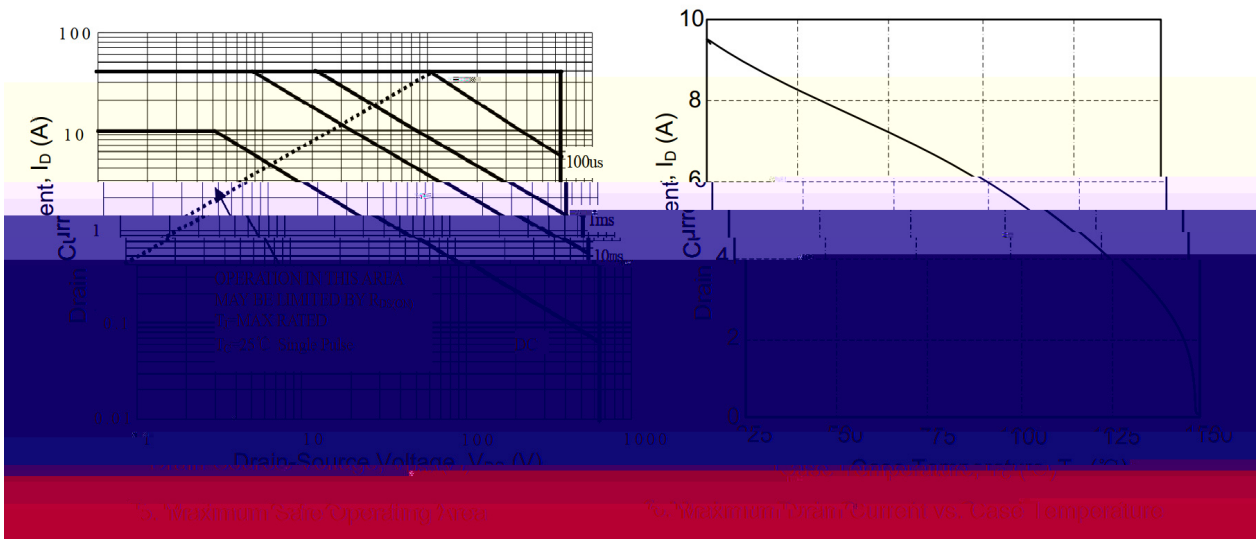

5. Maximum Safe Operating Area

6. Maximum Drain Current vs. Case Temperature

/ Package Dimensions

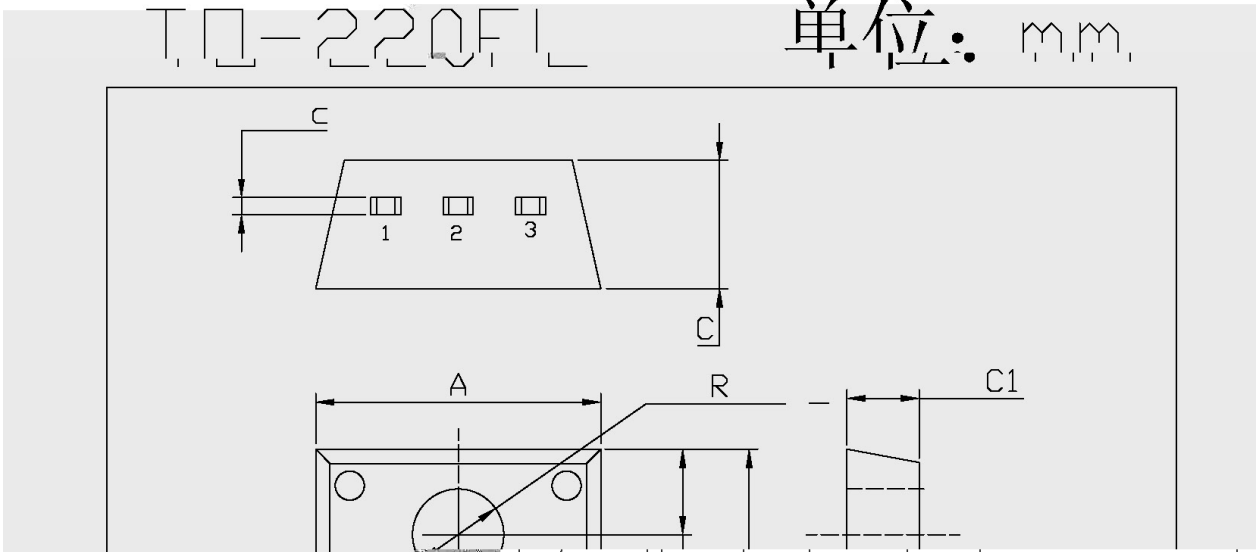

Symbol	Dimensions In Millimeters		Symbol	Dimensions In Millimeters	
	Min	Max		Min	Max
C	4.5	4.7	b1	2.90	3.90
C	0.4	0.6	a	1.08	1.48
A	9.56	10.56	a1	0.70	0.90
B	15.67	16.67	E	2.34	2.74
B1	3.30	3.50	E1	2.34	2.74
R	3.08	3.28	C1	2.34	2.74

/ Marking Instructions

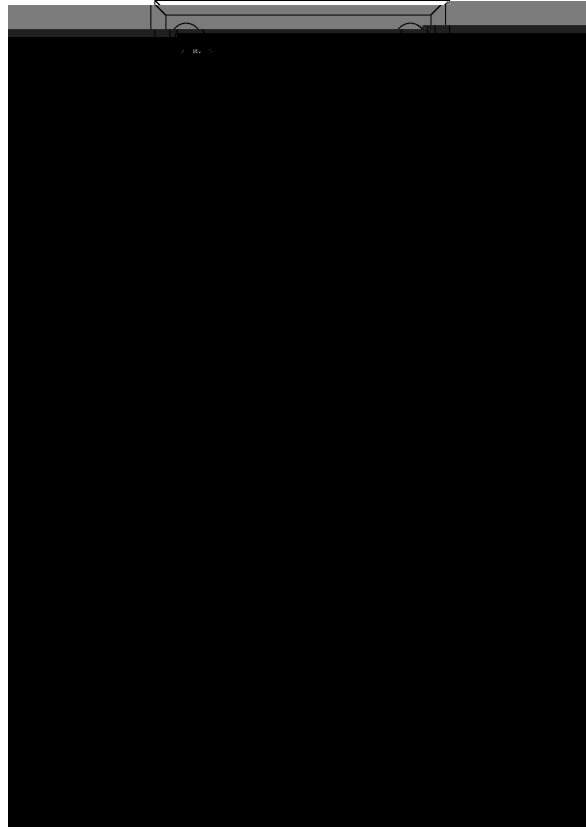

( ) / Temperature Profile for Dip Soldering(Pb-Free)
