



		μ				

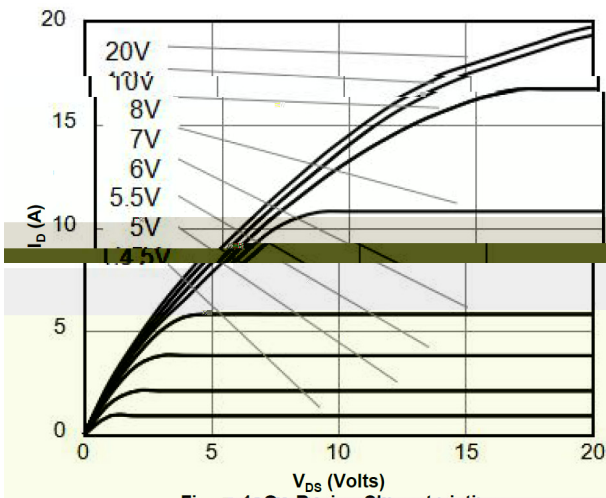

Figure 1: On-Region Characteristics

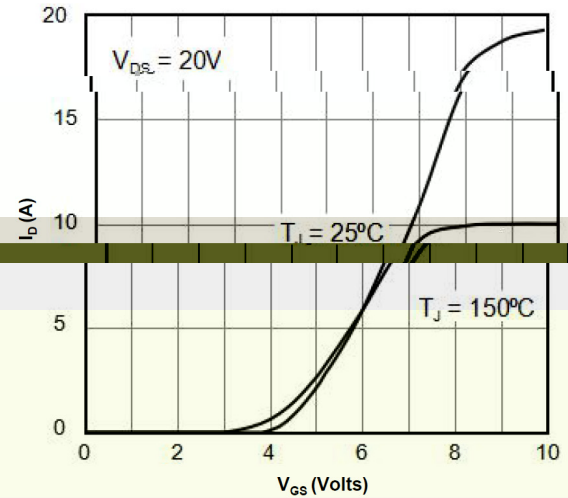

Figure 2: Transfer Characteristics

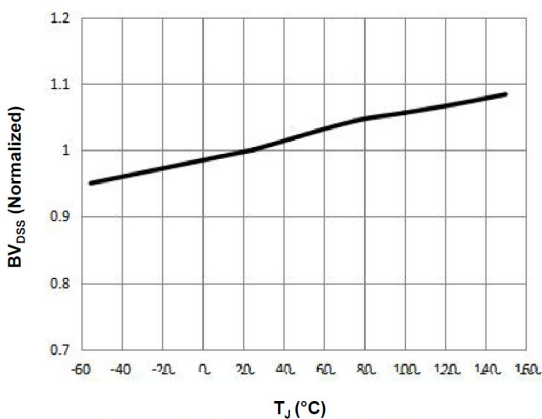
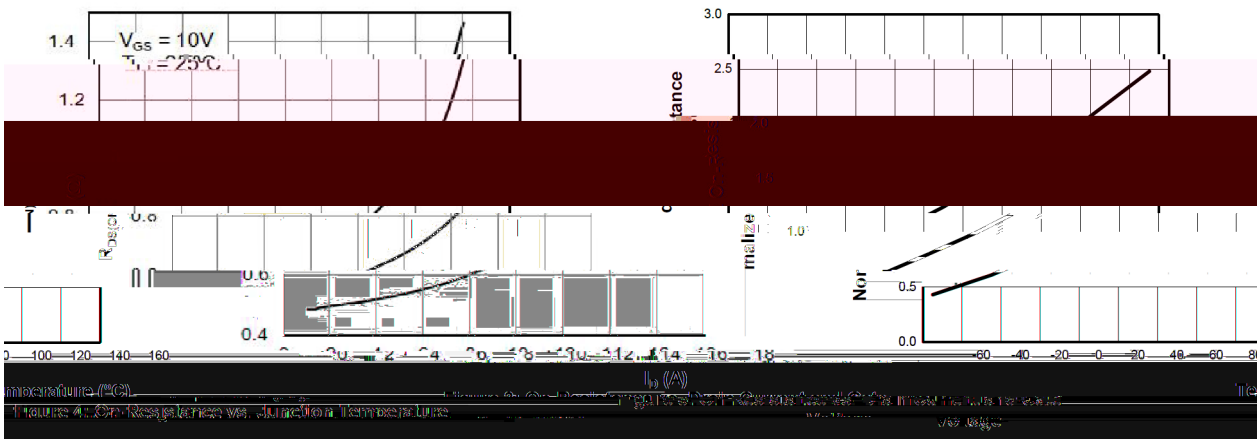

Figure 5: Break Down vs. Junction Temperature

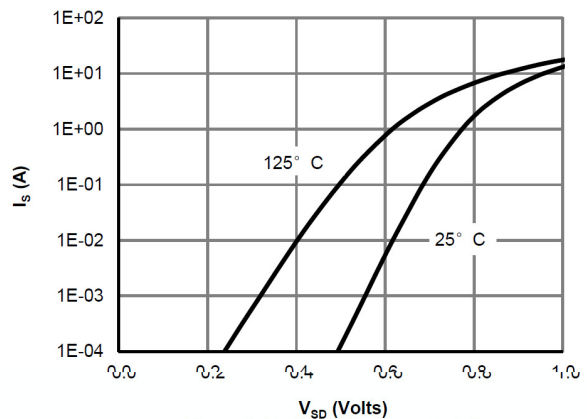

Figure 6: Body-Diode Characteristics

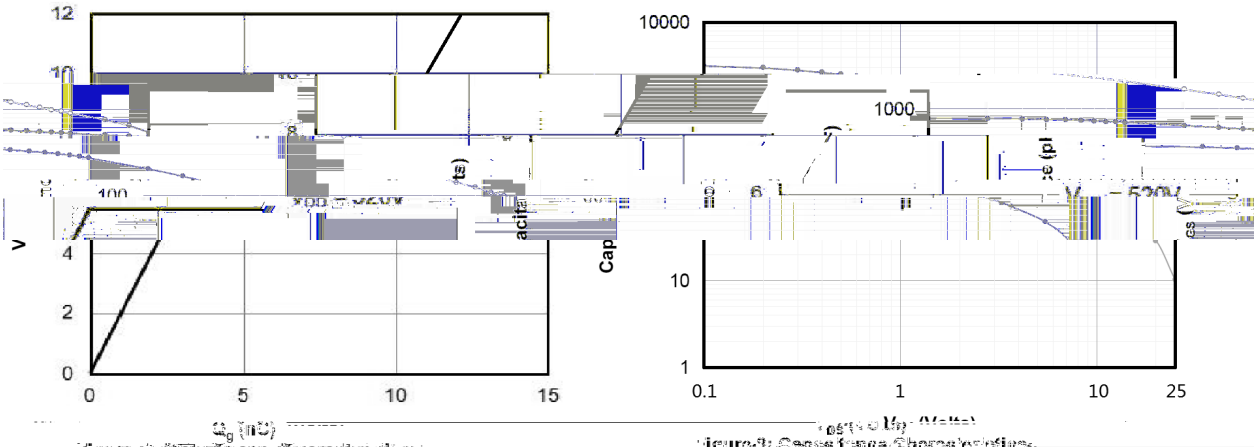

Figure 10: MOSFET Energy Characteristics

Figure 11: Capacitance Characteristics

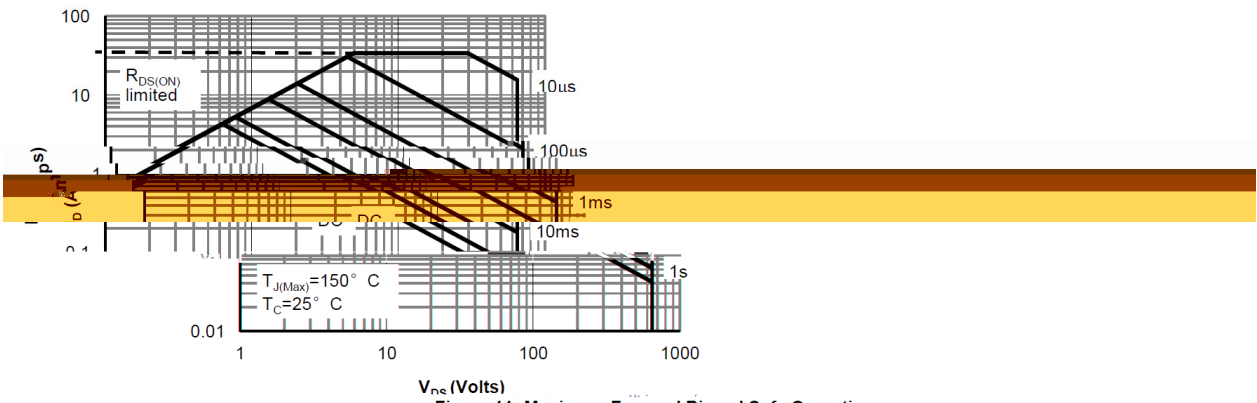
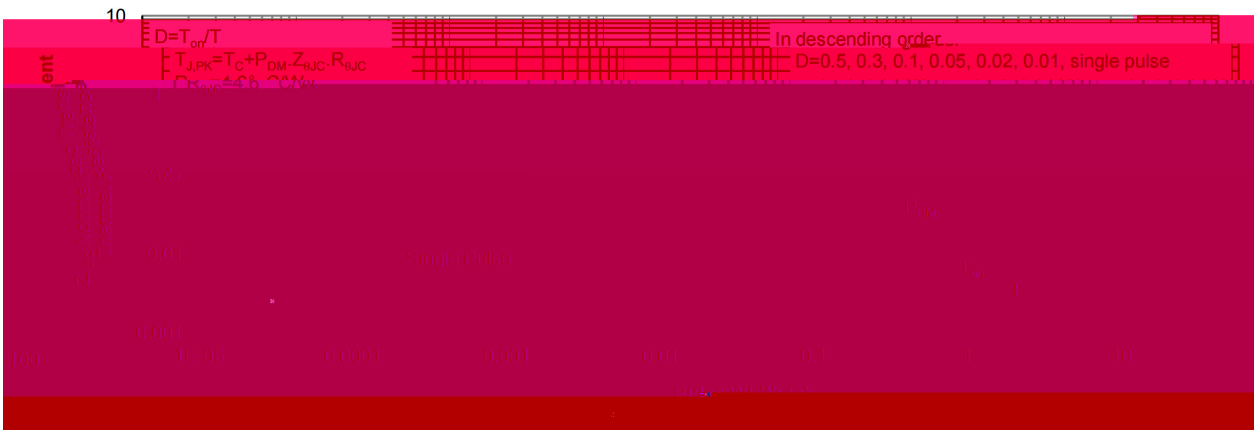
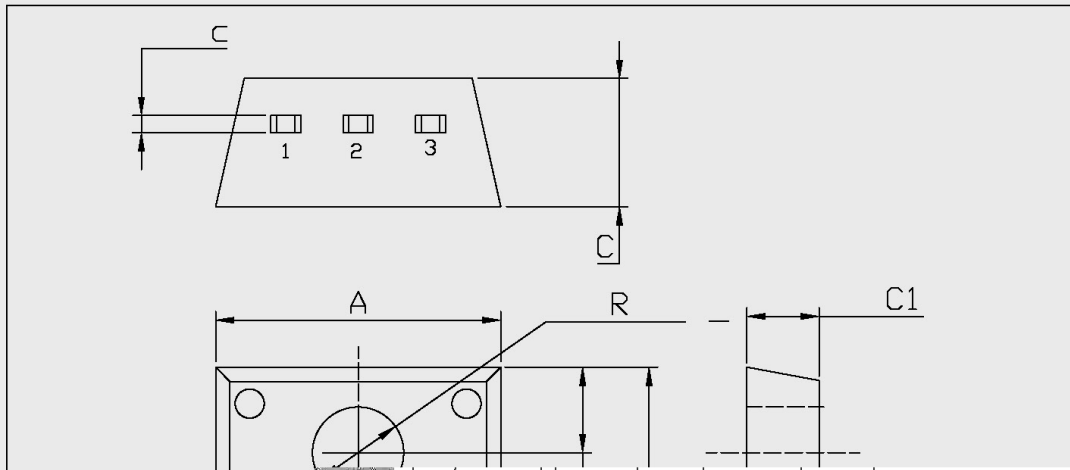

Figure 11: Maximum Forward Biased Safe Operating Area



TQ-220FL

单位: mm



Symbol	Dimensions In Millimeters		Symbol	Dimensions In Millimeters	
	Min	Max		Min	Max
C	4.5	4.7	b1	2.90	3.90
C	0.4	0.6	a	1.08	1.48
A	5.50	6.50	a1	0.70	0.90
B	5.50	6.50	E	2.34	2.74
B1	3.30	3.50	E1	2.34	2.74
R	3.08	3.28	C1	2.34	2.74

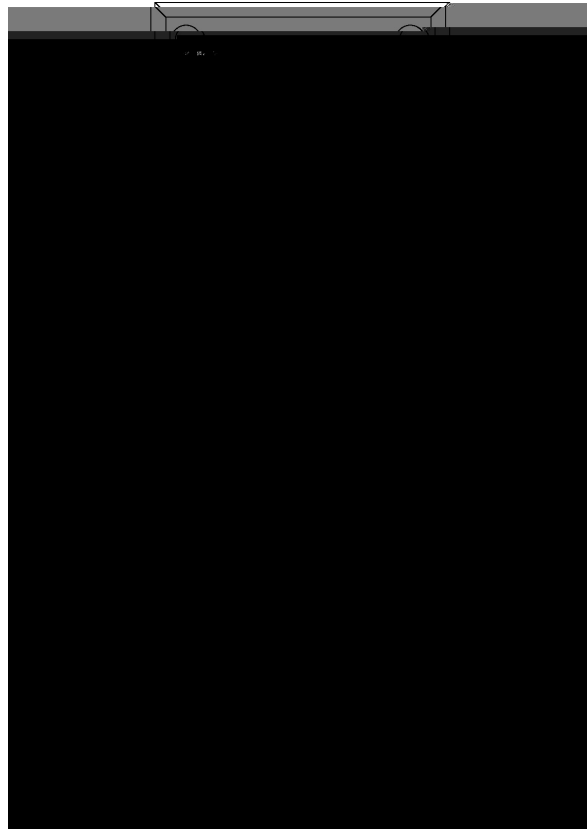

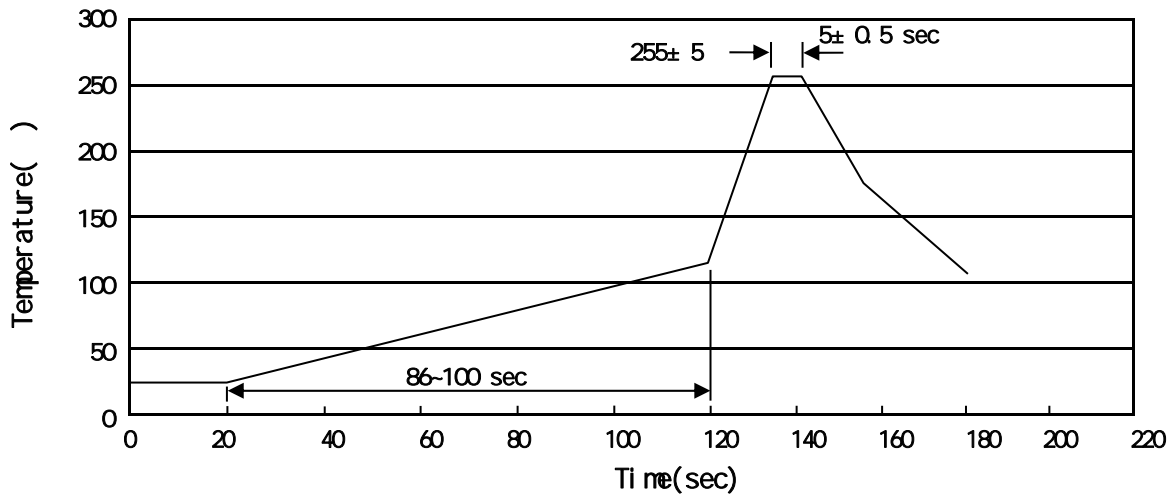

°C

	Units/Tube	Tubes/Inner Box	Units/Inner Box	Inner Boxes/Outer Box	Units/Outer Box	Tube	Inner Box	Outer Box
	/	/	/	/	/			