

# BRGB75P65AHA

Rev.A Jan.-2026

## / Descriptions

TO-247

Insulated-Gate Bipolar Transistor in a TO-247 Plastic Package.

## / Features

650V 75A

$V_{CE(SAT)} = 1.90V(\text{typ.}) @ V_{GE} = 15V, I_C = 75A$

## / Applications

Solar Converters, Uninterrupted Power Supply, Welding Converters, Mid to High Range Switching Frequency Converters.

## / Equivalent Circuit

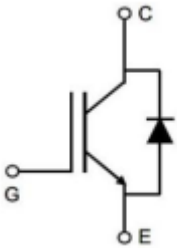

## / Pinning

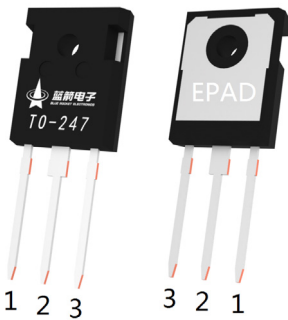

PIN1 G      PIN 2 EPAD C      PIN 3 E

## / Marking

See Marking Instructions.

/ Absolute Maximum Ratings( $T_a=25$  )

Parameter	Symbol	Rating	Unit	
Collector-Emitter Voltage	$V_{CES}$	650	V	
Gate-Emitter Voltage	$V_{GES}$	30	V	
Continuous Collector Current	$I_C$	$T_C=25$	150	A
		$T_C=100$	75	A
Pulsed Collector Current , Limited by $T_{Jmax}$	$I_{CM}$	300	A	
Continuous Diode Forward Current	$I_F$	$T_C=25$	160	A
		$T_C=100$	80	A
Power Dissipation	$P_D$	$T_C=25$	750	W
		$T_C=100$	375	W
Operating Junction Temperature Range	$T_J$	-40 to +175		
Storage Temperature Range	$T_{STG}$	-55 to +150		
Maximum Junction-to-Ambient	$R_{\theta JA}$	80	/W	
Maximum IGBT Junction-to-Case	$R_{\theta JC}$	0.20	/W	
Maximum Diode Junction-to-Case	$R_{\theta JC}$	0.55	/W	

/ Electrical Characteristics( $T_c=25$  )

Parameter	Symbol	Test Conditions	Min	Typ	Max	Unit
Collector-Emitter Breakdown Voltage	$BV_{CES}$	$I_C=250\mu A, V_{GE}=0V$	650			V
Zero Gate Voltage Collector current	$I_{CES}$	$V_{CE}=650V, V_{GE}=0V$			250	$\mu A$
Gate-Emitter Leakage Current	$I_{GES}$	$V_{CE}=0V, V_{GE}=\pm 30V$			100	nA
Gate-Emitter Threshold Voltage	$V_{GE(th)}$	$V_{CE}=V_{GE}, I_C=250\mu A$	4.0	5.0	5.5	V
Collector-Emitter Saturation Voltage	$V_{CE(sat)}$	$V_{GE}=15V, I_C=75A$	$T_J=25$	1.90	2.20	V
			$T_J=125$	2.00		
Total Gate Charge	$Q_g$	$V_{GE}=15V, V_{CE}=480V, I_C=75A$		200		nC
Gate to Emitter Charge	$Q_{ge}$			20		
Gate to Collector Charge	$Q_{gc}$			32		

## / Electrical Characteristics(Ta=25 )

Parameter	Symbol	Test Conditions		Min	Typ	Max	Unit
Turn-On Delay Time	$t_{d(on)}$	$V_{GE}=15V,$ $V_{CC}=400V$ $I_C=75A,$ $R_G=10\Omega$ Inductive Load	TC=25		38		ns
			Tc=150		36		ns
Turn-On Rise Time	$t_r$		TC=25		118		ns
			Tc=150		100		ns
Turn-Off Delay Time	$t_{d(off)}$		TC=25		267		ns
			Tc=150		300		ns
Turn-Off Fall Time	$t_f$		TC=25		81		ns
			Tc=150		85		ns
Turn-On Energy	$E_{on}$		TC=25		4.65		mJ
			Tc=150		4.50		mJ
Turn-Off Energy	$E_{off}$	TC=25		2.45		mJ	
		Tc=150		2.70		mJ	
Total Switching Energy	$E_{ts}$	TC=25		7.10		mJ	
		Tc=150		7.20		mJ	
Input Capacitance	$C_{ies}$	$V_{GE}=0V,$ $f=1MHz$	$V_{CE}=25V$		2850		pF
Output Capacitance	$C_{oes}$				410		pF
Reverse Transfer Capacitance	$C_{res}$				185		pF
Diode Forward Voltage	$V_F$	$I_F=75A$	$T_J=25$		1.50		V
			$T_J=125$		1.35		
Diode Reverse Recovery Time	$T_{rr}$	$V_R=400V,$ $I_F=75A$ $di_F/dt=500$ $A/us$	TC=25		80		ns
			Tc=150		125		ns
Diode Reverse Recovery Charge	$Q_{rr}$		TC=25		0.58		$\mu C$
			Tc=150		1.25		$\mu C$
Diode Peak Reverse Recovery Current	$I_{rm}$		TC=25		12.5		A
			Tc=150		18.5		A

/ Electrical Characteristic Curve

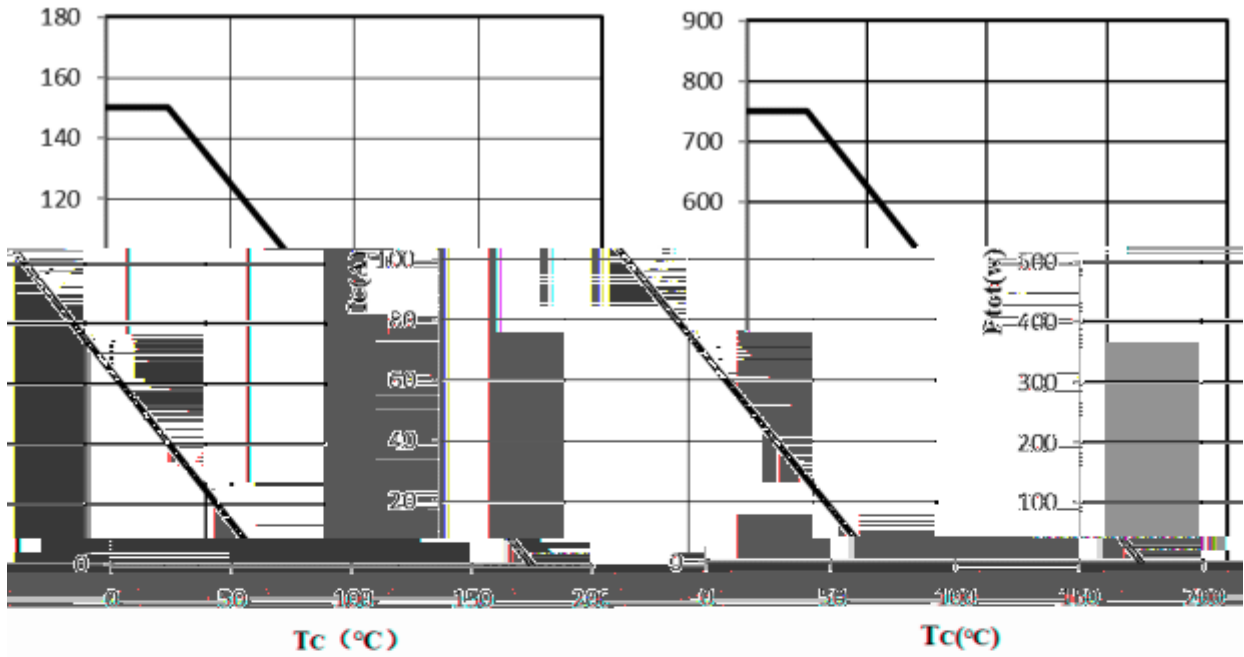

Fig 2. Power dissipation as a function of case

Fig 1. DC Collector current as a function of case

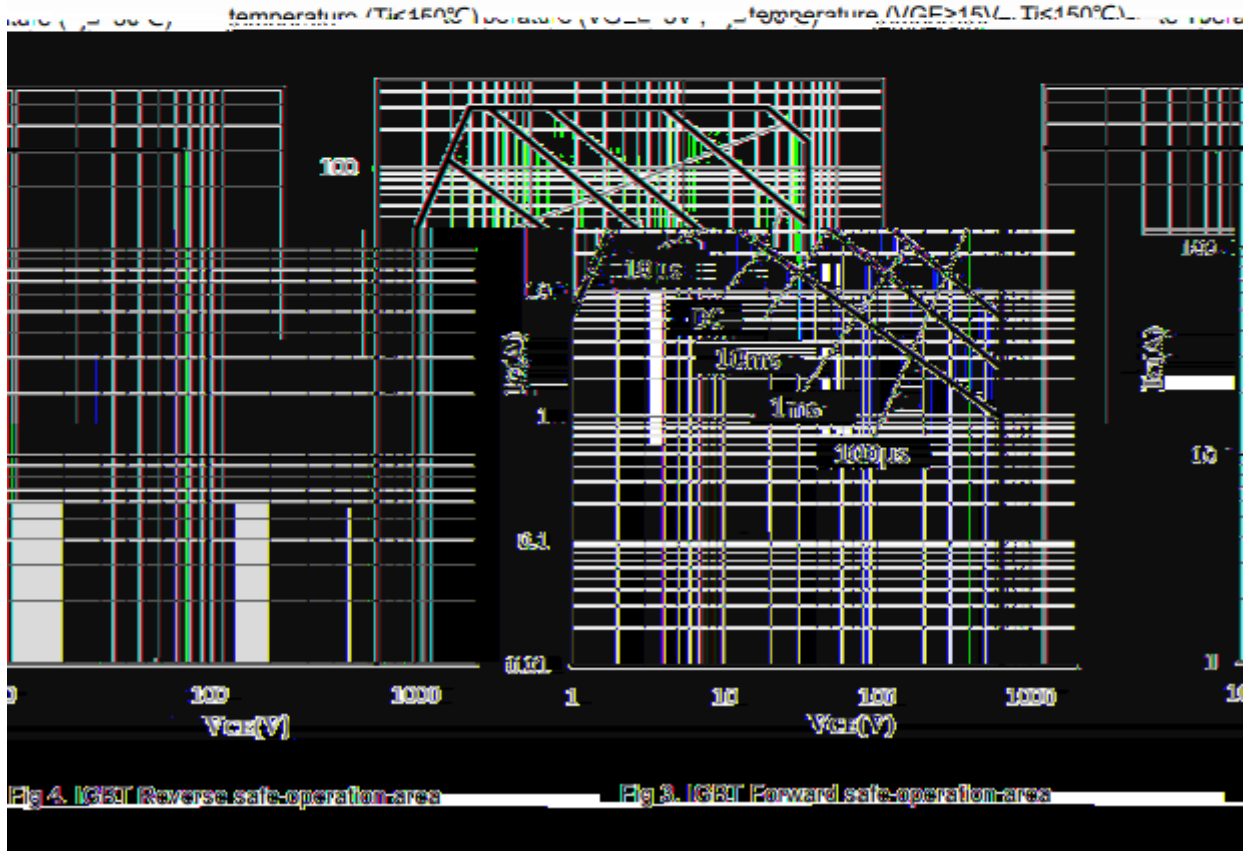

Fig 4. IGBT Reverse safe-operation area

Fig 3. IGBT Forward safe-operation area

/ Electrical Characteristic Curve

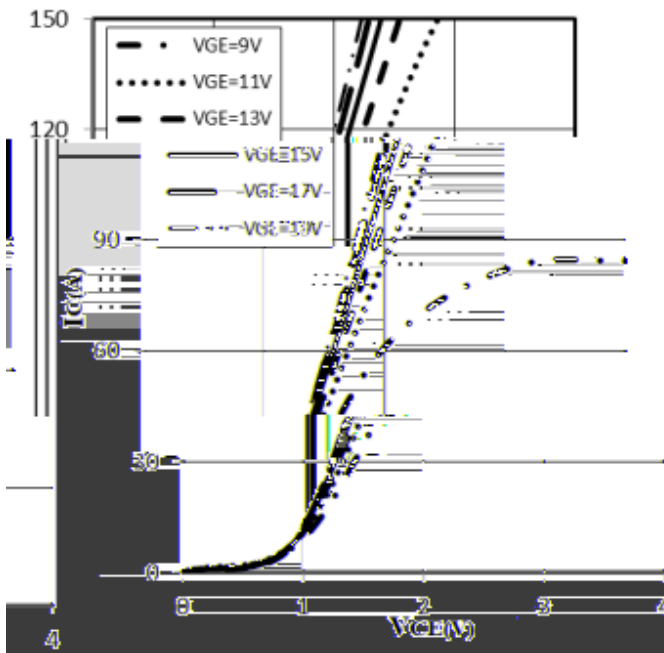

Fig. 5. Typical output characteristic (CI-023)

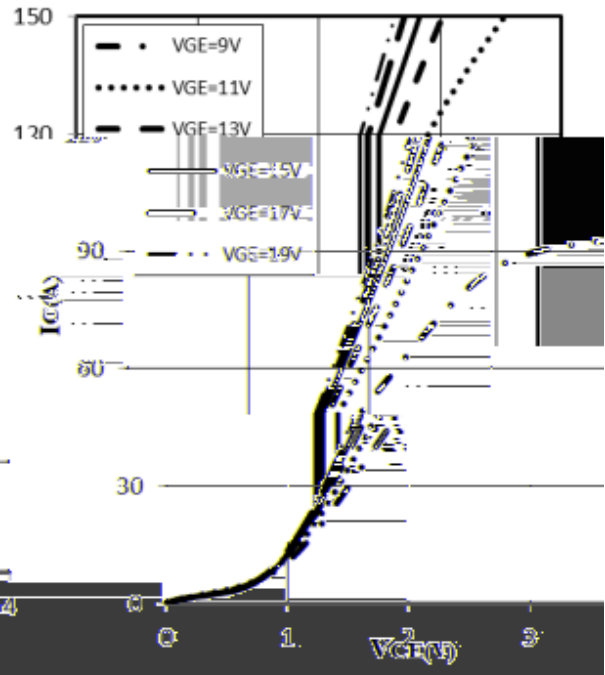

Fig. 6. Typical output characteristic (CI-123)

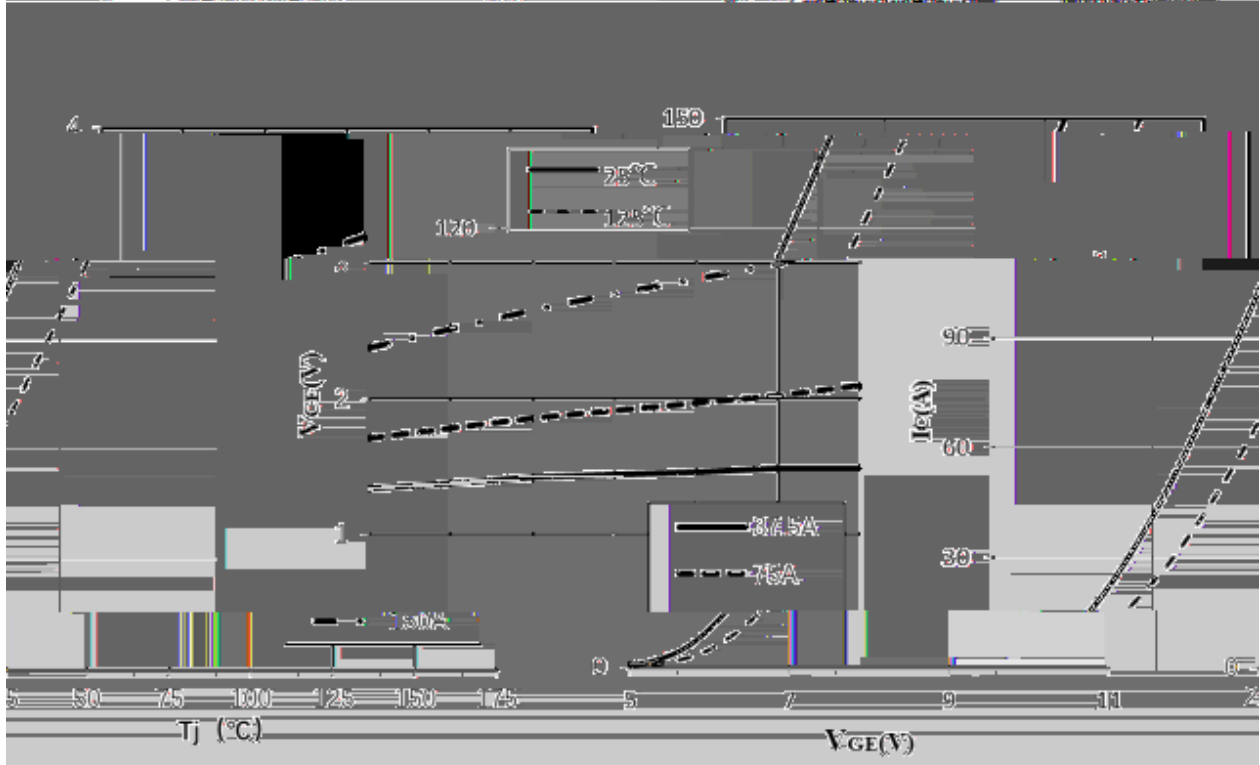
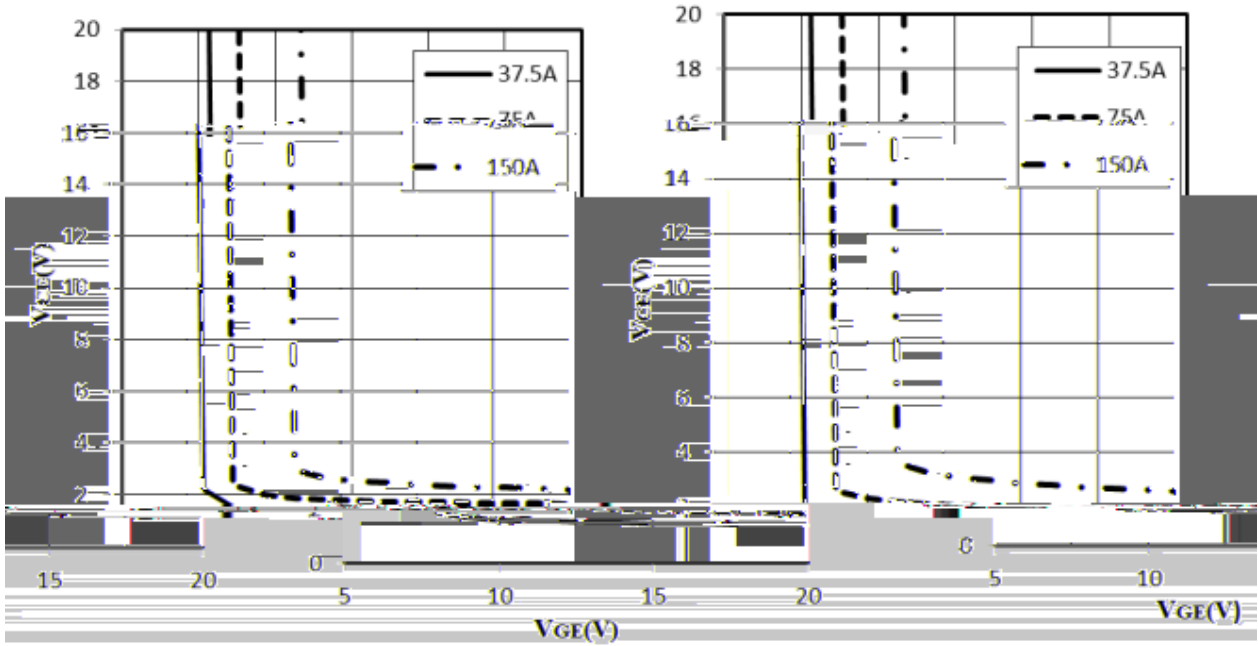

Fig. 7. Typical transfer characteristic ( $V_{CE} = 20V$ )

Fig. 8. Typical collector-emitter saturation voltage as a function of junction temperature ( $V_{GE} = 15V$ )

/ Electrical Characteristic Curve



saturation voltage as a function of  $V_{GE}$  ( $I_C=150A$ )

Fig 10. Typical collector-emitter saturation voltage as a function of  $V_{GE}$  ( $I_C=150A$ )

Fig 9. Typical collector-emitter saturation voltage as a function of  $V_{GE}$  ( $I_C=150A$ )

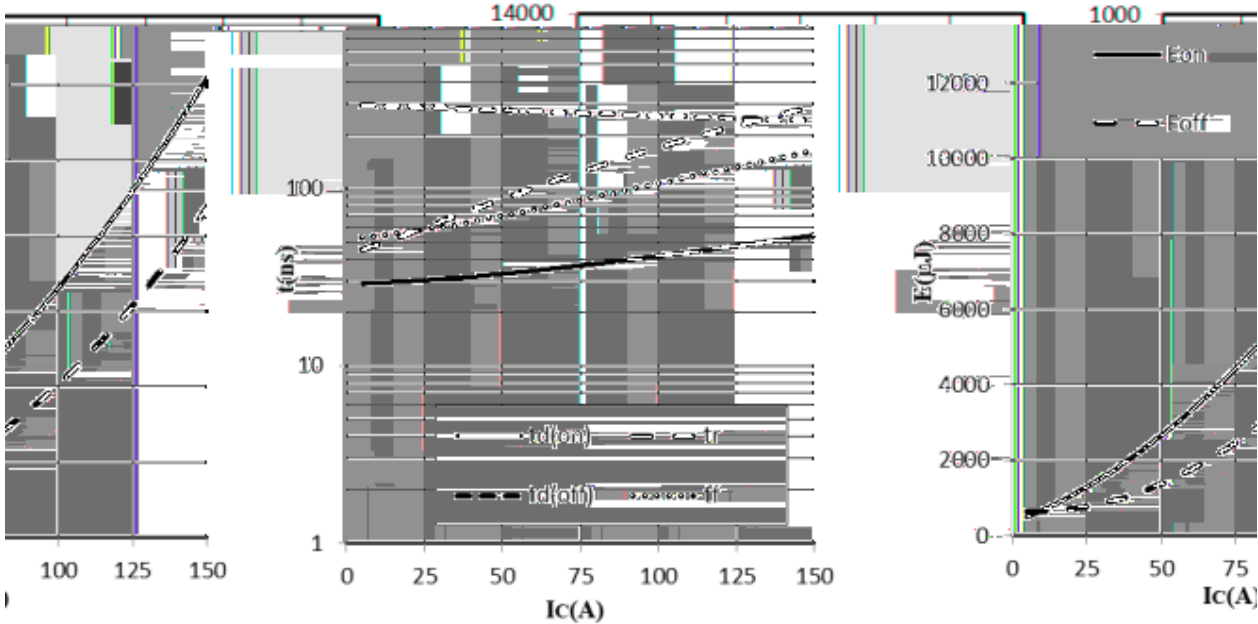

as a function of  $I_C$

Fig 12. Typical switch time as a function of  $I_C$

Fig 11. Typical switch energy as a function of  $I_C$

$V_{CE} = 15V, P_{avg} = 100W$

(Inductive Load,  $T_c = 35^\circ C, M_{ce} = 400V, V_{GE} = 15V, P_{avg} = 100W$ )

(Inductive Load,  $T_c = 35^\circ C, M_{ce} = 400V$ )

/ Electrical Characteristic Curve

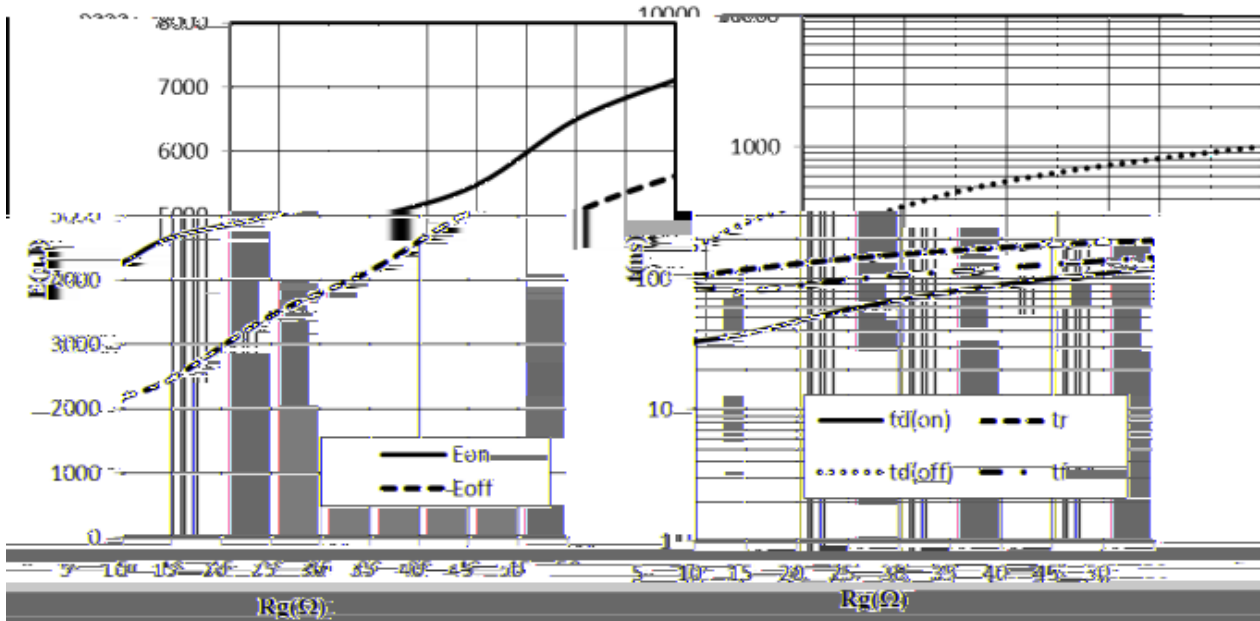

Fig 13. Typical switch energy as a function of  $R_g$

Fig 14. Typical switch time as a function of  $R_g$

inductive load,  $T_j=25^\circ\text{C}$ ,  $V_{CE}=400\text{V}$ ,  $V_{GE}=15\text{V}$ ,  $I_C=75\text{A}$

(inductive load,  $T_j=25^\circ\text{C}$ ,  $V_{CE}=400\text{V}$ ,  $V_{GE}=15\text{V}$ ,  $I_C=75\text{A}$ )

(i)

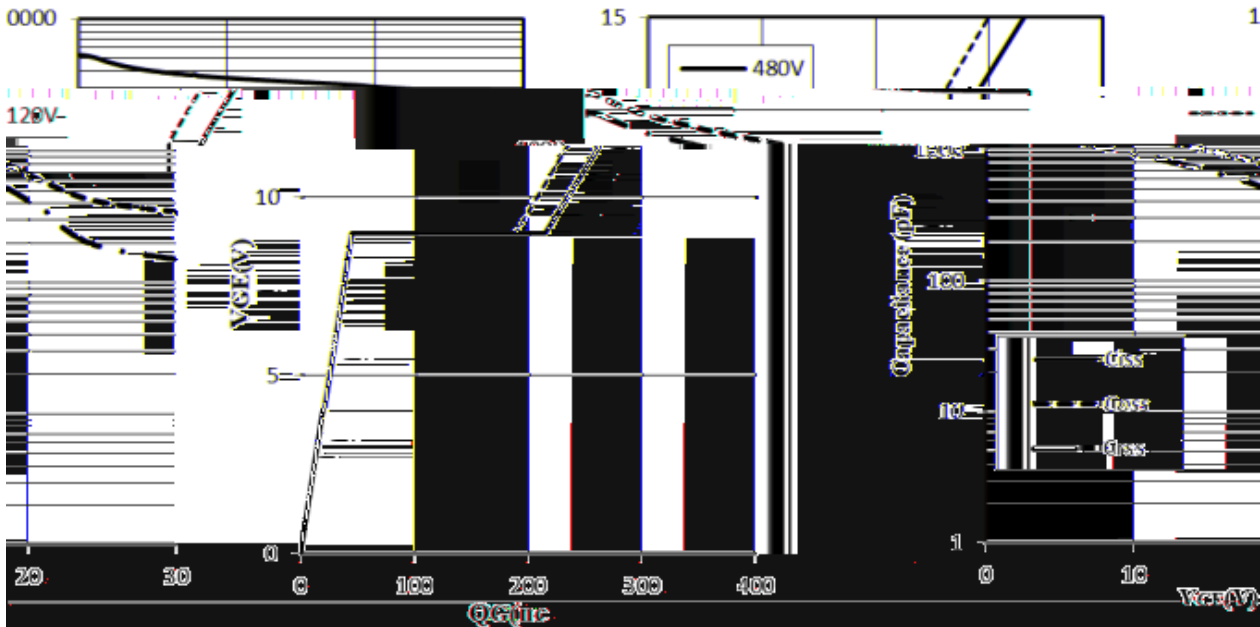

function of collector

Fig 16. Typical gate charge ( $I_C=75\text{A}$ )

Fig 15. Typical capacitance as a

$V_{GE}=15\text{V}$ ,  $f=1\text{MHz}$

emitter voltage ( $V_{GE}=0$ )

/ Electrical Characteristic Curve

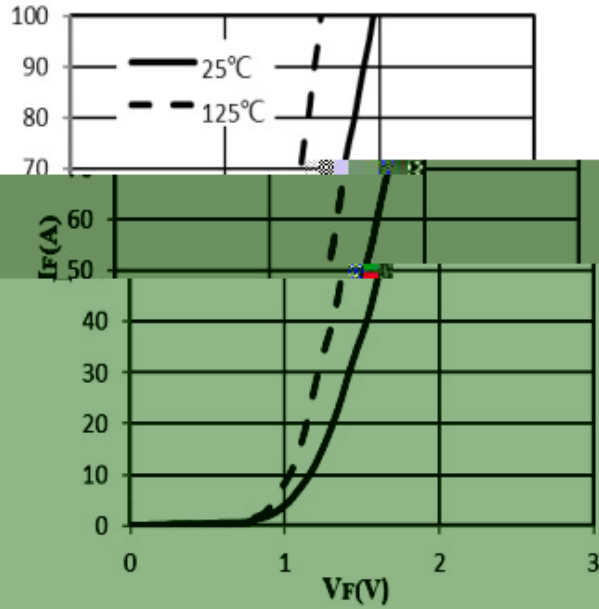

Fig 17. Typical diode forward current as a function of forward voltage

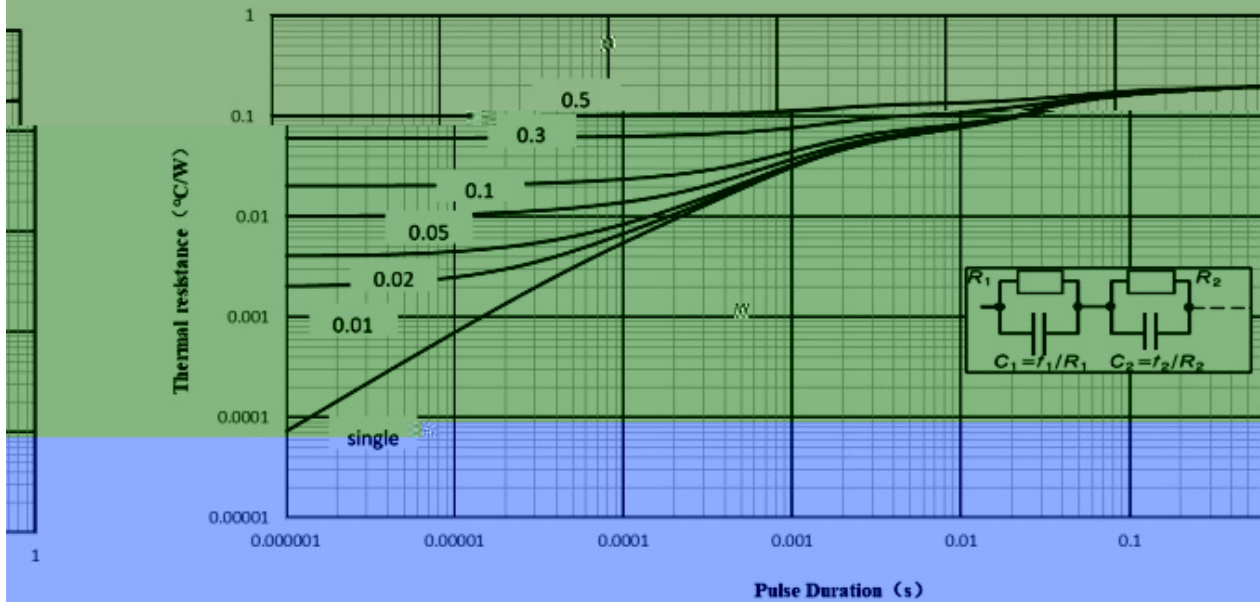
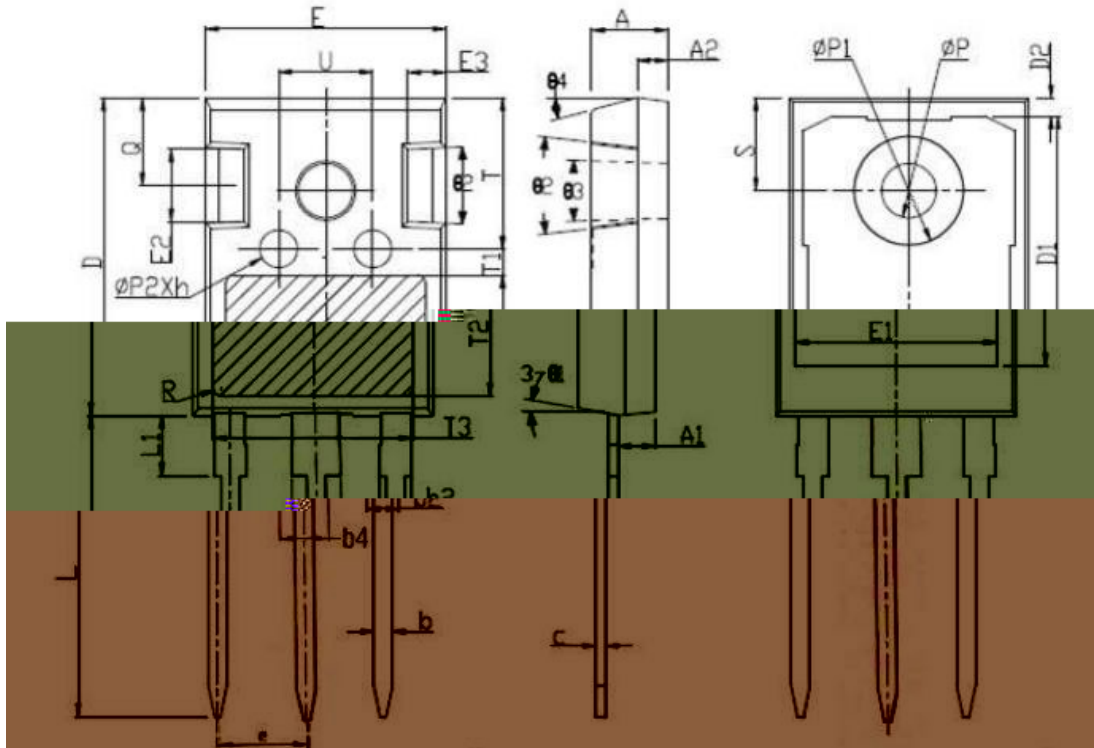

Fig 18. IGBT transient thermal resistance( $D=I_p/T$ )

# BRGB75P65AHA

Rev.A Jan.-2026

## / Package Dimensions



Symbol	Min	Nom	Max	Symbol	Min	Nom	Max
A	4.9	5.0	5.1	e	5.44BSC		
A1	2.3	2.4	2.5	h	0.05	0.10	0.15
A2	1.9	2.0	2.1	L1	19.6	19.9	20.2
b	1.10	1.20	1.25	Φp	3.5	3.6	3.75
b2	1.90	2.00	2.25	Φp1	7.0	7.3	7.6
b4	2.90	3.00	3.25	Φp2	2.4	2.5	2.6
c	0.50	0.60	0.70	Q	5.3	5.9	6.5
D	20.8	21.0	21.2	S	6.15BSC		
D1	16.25	16.55	16.85	T	9.8	10.2	10.6
D2	1.05	1.20	1.35	T1	1.65REF		
E	15.6	15.8	16.0	T2	8.0REF		
E1	13.1	13.3	13.5	T3	12.8REF		
E2	4.9	5.0	5.1	U	6.0	6.4	6.8
E3	2.4	2.5	2.6				
Unit	mm			type	TO-247G		

## / Marking Instructions

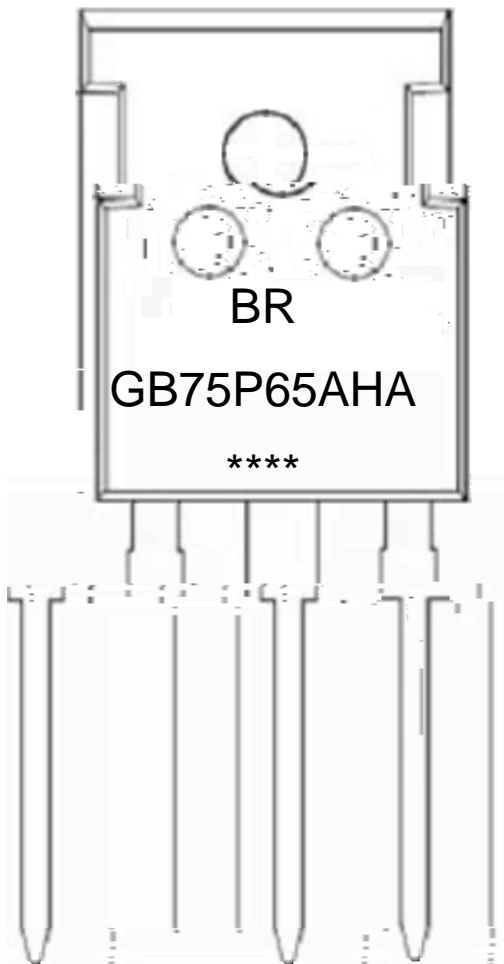

BR

GB75P65AHA

\*\*\*\*

Note:

BR: Company Code

GB75P65AHA: Product Type Code

\*\*\*\*: Lot No. Code, code change with Lot No

( ) / Temperature Profile for Dip Soldering(Pb-Free)

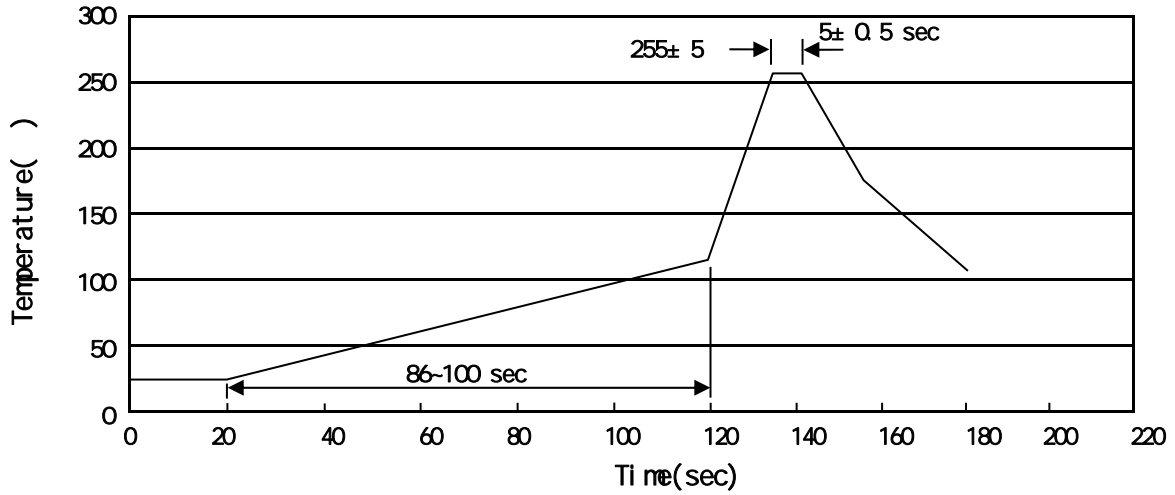

Note:

- |   |          |             |   |
|---|----------|-------------|---|
| 1 | 25 ~ 150 | 60 ~ 90sec; | 1.Preheating:25~150 , Time:60~90sec.    |
| 2 | 255±5    | 5±0.5sec;   | 2.Peak Temp.:255±5 , Duration:5±0.5sec. |
| 3 | 2 ~ 10   | /sec.       | 3. Cooling Speed: 2~10 /sec.            |

/ Resistance to Soldering Heat Test Conditions

270±5                      10±1 sec.                      Temp.:270±5°C                      Time:10±1 sec

/ Packaging SPEC.

/ TUBE

Package Type	Units					Dimension (unit mm <sup>3</sup> )		
	Units/Tube	Tubes/Inner Box	Units/Inner Box	Inner Boxes/Outer Box	Units/Outer Box	Tube	Inner Box	Outer Box
TO-247	30	15	450	5	2250	520×44×6	580×158×55	595×300×178

/ Notices

All information provided in this document is subject to legal disclaimers.