

BRLV30T50ABD

Rev. D Apr.-2020

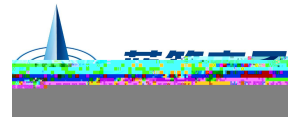

DATA SHEET

B	2018-7				
C	2019-10-25				

BRLV30T50ABD

Rev. D Apr.-2020

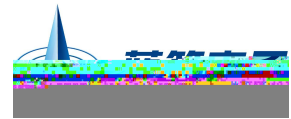

DATA SHEET

描述 / Descriptions

TO-263

Schottky Barrier Diode in a TO-263 Plastic Package.

特征 / Features

Low forward voltage drop, low power losses, High efficiency operation. HF Product.

用途 / Applications

OR-ing

DC-DC

For use in solar cell junction box as a bypass diode for protection, For use in high frequency inverters, switching power supplies, freewheeling diodes, OR-ing diode, dc-to-dc converters and reverse battery protection.

内部等效电路 / Equivalent Circuit

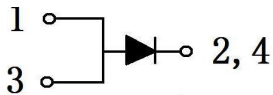

引脚排列 / Pinning

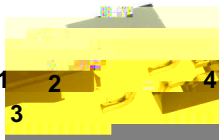

PIN1 Anode

PIN 2 4 Cathode

PIN 3 Anode

放大及印章代码 / h_{FE} Classifications & Marking

See Marking Instructions.

BRLV30T50ABD

Rev. D Apr.-2020

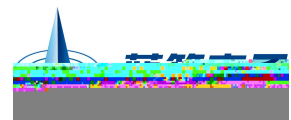

DATA SHEET

Parameter	Symbol	Rating	Unit
Maximum repetitive peak reverse voltage	V_{RRM}	50	V

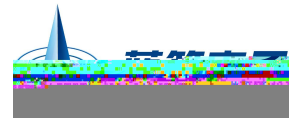

电参数曲线图 / Electrical Characteristic Curve

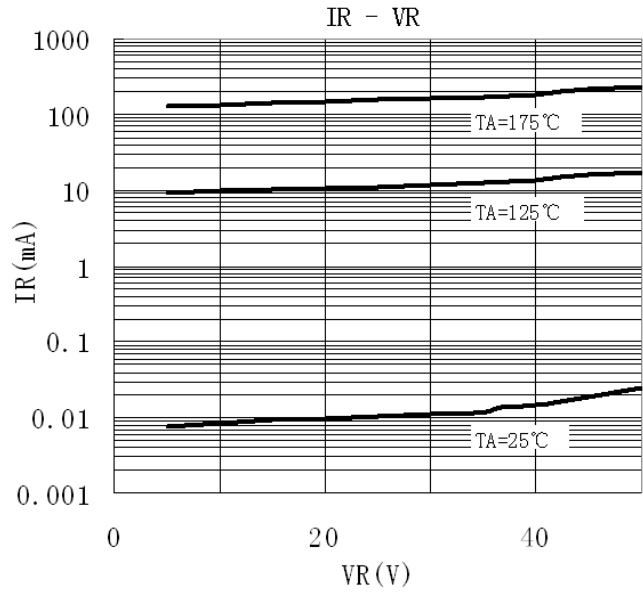
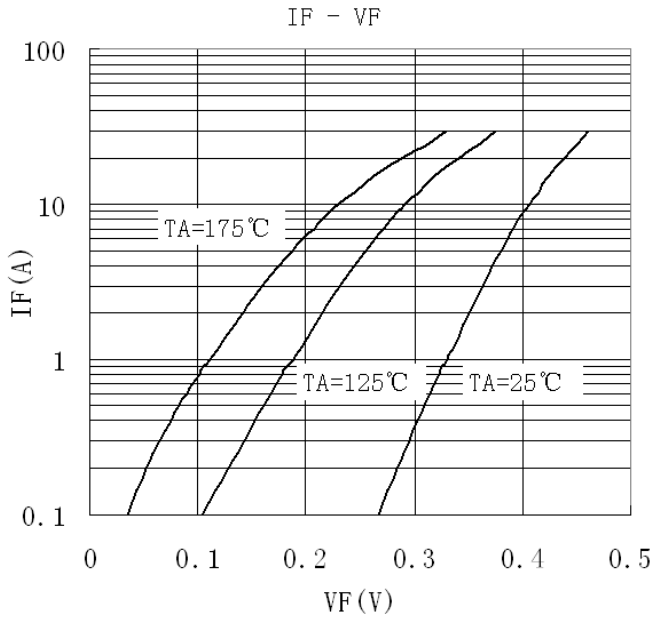

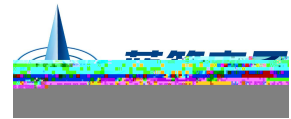

外形尺寸图 / Package Dimensions

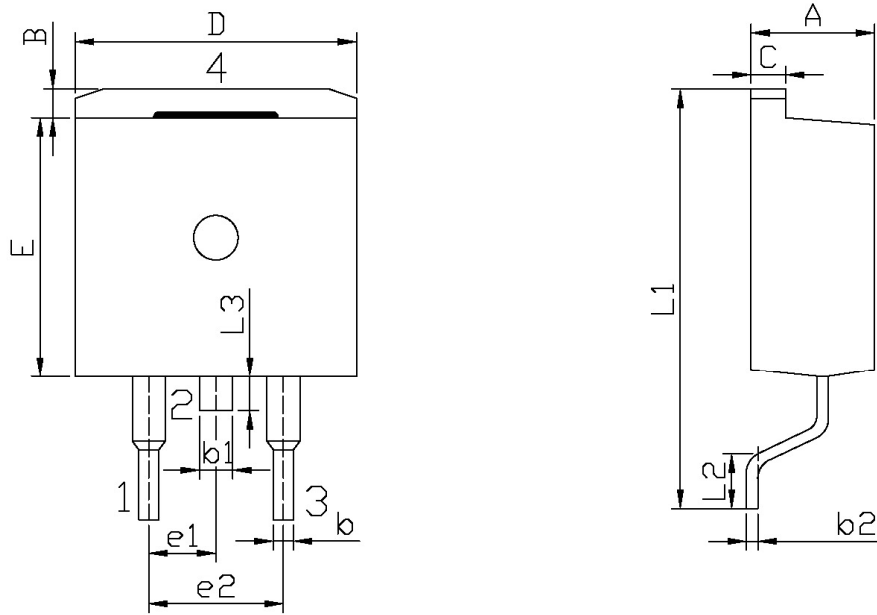

单位: mm

Symbol	Dimensions In Millimeters		Symbol	Dimensions In Millimeters	
	Min	Max		Min	Max
A	4.30	4.70	E	9.00	9.40
B	1.00	1.40	e1	2.34	2.74
b	0.70	0.90	e2	4.88	5.28
b1	1.15	1.35	L1	15.00	16.00
b2	0.40	0.60	L2	2.24	2.84
C	1.20	1.40	L3	1.20	1.60
D	9.80	10.20			

T1-253

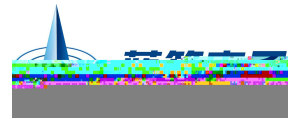

印章说明 / Marking Instructions

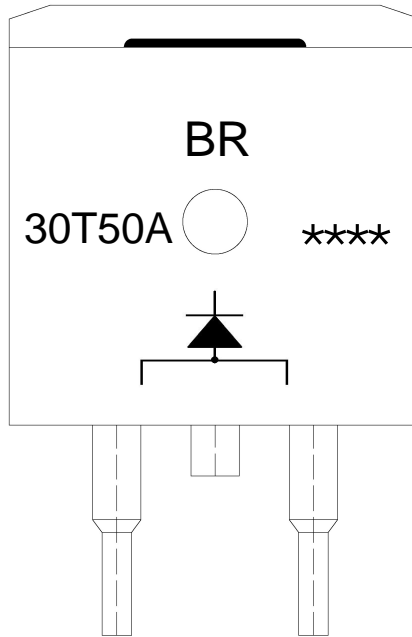

说明：

BR： 为公司代码

30T50A： 为型号代码

： 为内部结构

****： 为生产批号代码，随生产批号变化。

Note:

BR: Company Code

30T50A: Product Type Code.

: Internal Structure

****: Lot No. Code, code change with Lot No.

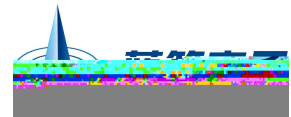

回流焊温度曲线图(无铅) / Temperature Profile for IR Reflow Soldering(Pb-Free)

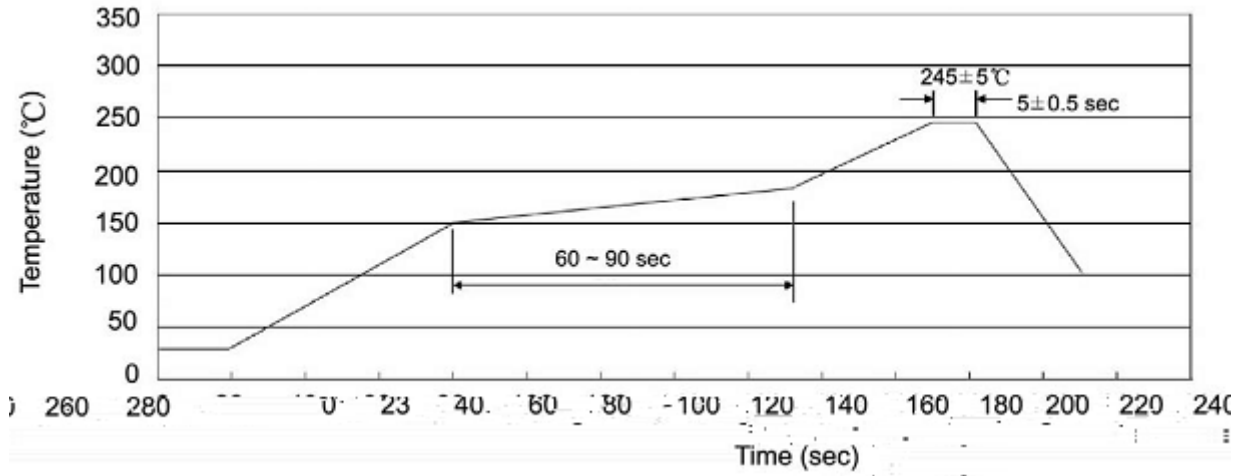

Note:

- 1. Preheating: 25~150 , Time: 60~90sec.
- 2. Peak Temp.: 245 ± 5 , Duration: 5 ± 0.5sec.
- 3. Cooling Speed: 2~10 /sec.

耐焊接热试验条件 / Resistance to Soldering Heat Test Conditions

□ 260 ± 5 □ 10 ± 1 sec. Temp.: 260 ± 5 °C Time: 10 ± 1 sec

包装规格 / Packaging SPEC.

/ TUBE

Package Type	Unit Dimension				Dimension (unit mm ³)			
	Units/Tube 只/套管	Tubes/Inner Box 套管/盒	Units/Inner Box 只/盒	Inner Boxes/Outer Box 盒/箱	Units/Outer Box 只/箱	Tube	Inner Box	Outer Box
					5,000	532×33×7.0	555×164×50	