

3.0A

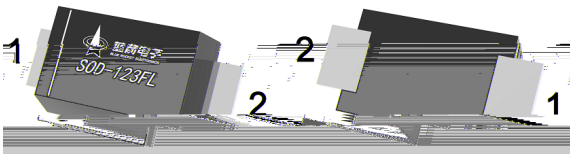

PIN	DESCRIPTION
1	Cathode
2	Anode

The recommended mounting pad size

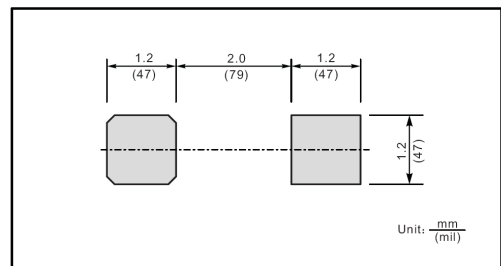



	()		
)			
	θ		°C
			°C
			°C



			数值	
		°C		
		°C		

Fig.1 Forward Current Derating Curve

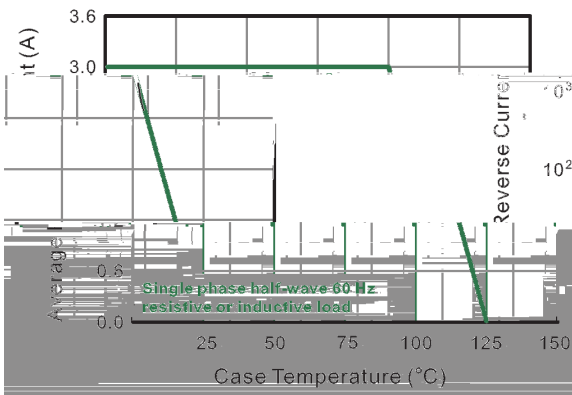

Fig.2 Typical Reverse Characteristics

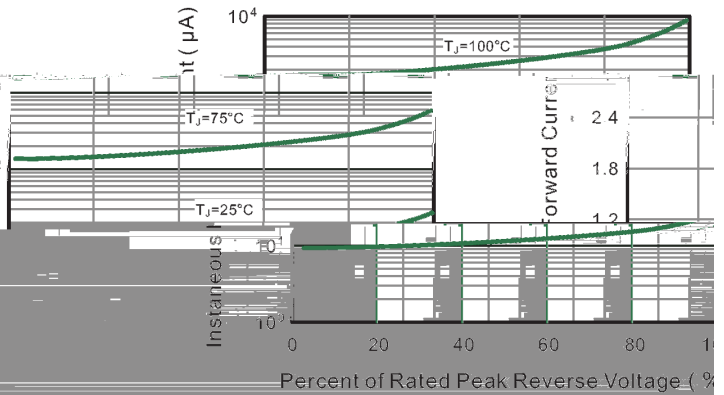

Fig.3 Typical Forward Characteristic

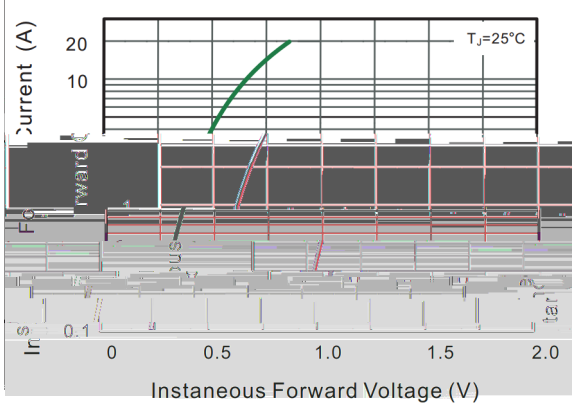

Fig.4 Typical Junction Capacitance

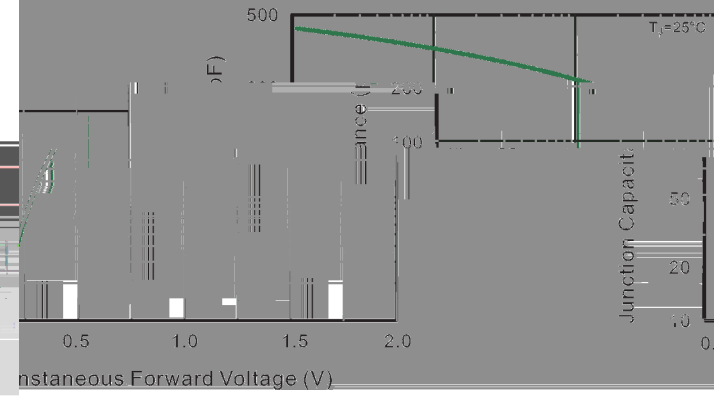

Fig.5 Typical Transient Thermal Impedance

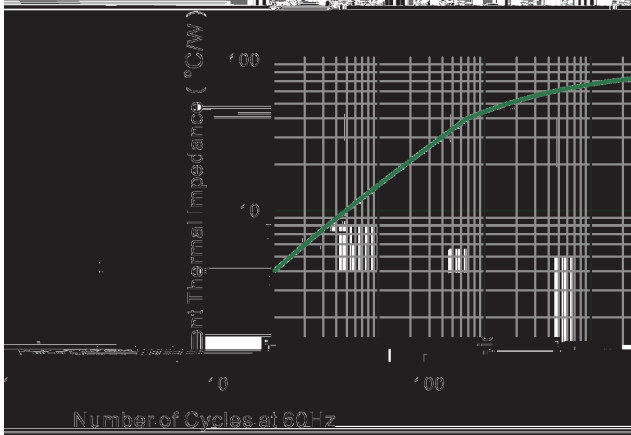
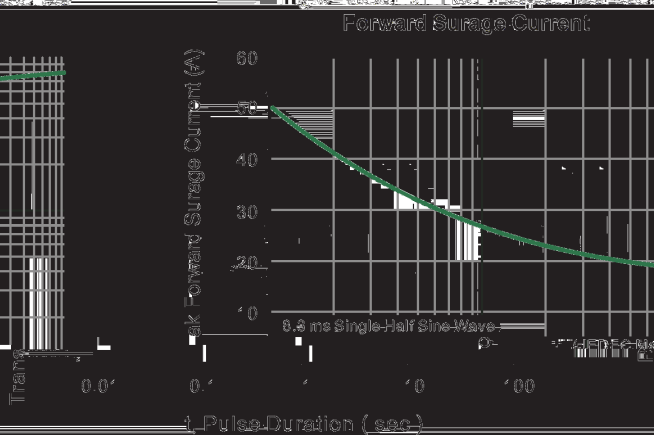
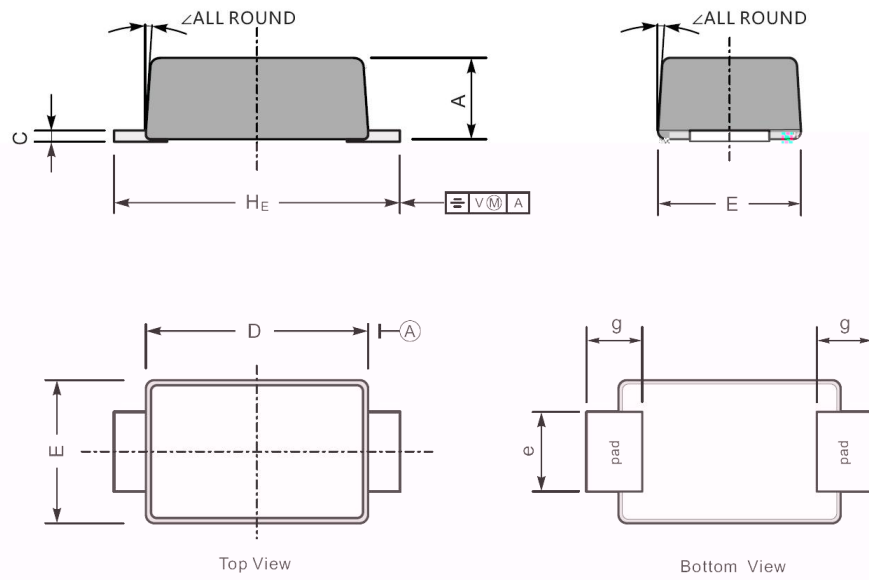

Fig.6 Maximum Non-Repetitive Peak



SOD-123FL



UNIT		A	C	D	E	e	g	H_E	\angle
mm	max	1.1	0.20	2.9	1.9	1.1	0.9	3.8	7°
	min	0.9	0.12	2.6	1.7	0.8	0.7	3.5	
mil	max	43	7.9	114	75	43	35	150	
	min	35	4.7	102	67	31	28	138	

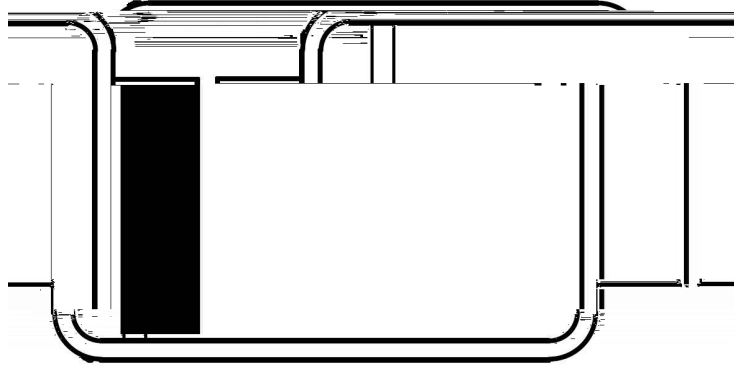

34L

34L

