

/ Descriptions

SMAF

Surface Mount Schottky Barrier Rectifier, Reverse Voltage: 100V, Forward Current:2.0A ,SMAF thin package.

/ Features

Low power loss, high efficiency, High forward surge current capability, For use in low voltage, high frequency inverters, and polarity protection applications,For surface mounted applications,HF Product.

/ Applications

General purpose.

/ Equivalent Circuit



/ Pinning

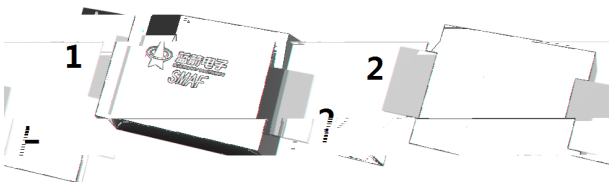

| PIN | DESCRIPTION |
|-----|-------------|
| 1 | Cathode |
| 2 | Anode |

The recommended mounting pad size

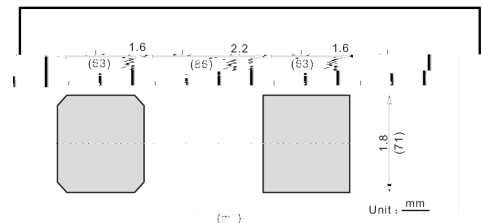

/ Marking

See Marking Instructions.

| Parameter | Symbol | Rating | Unit |
|-----------------------------------------|-----------|--------|------|
| Maximum Repetitive Peak Reverse Voltage | V_{RRM} | 100 | V |
| Maximum RMS voltage | V_{RMS} | 70 | V |
| Maximum DC Blocking Voltage | $VRMS$ | | |

/ Electrical Characteristic Curve

Fig.1 Forward Current Derating Curve

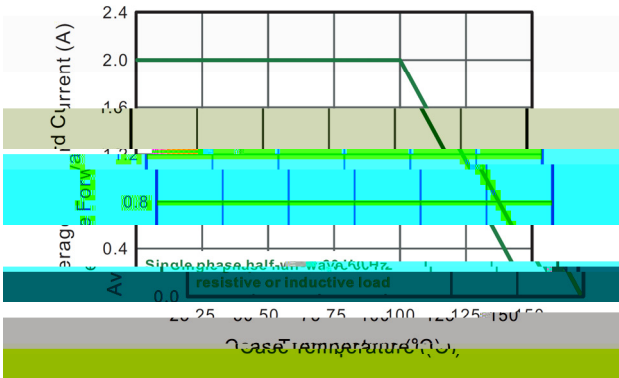

Fig.2 Typical Reverse Characteristics

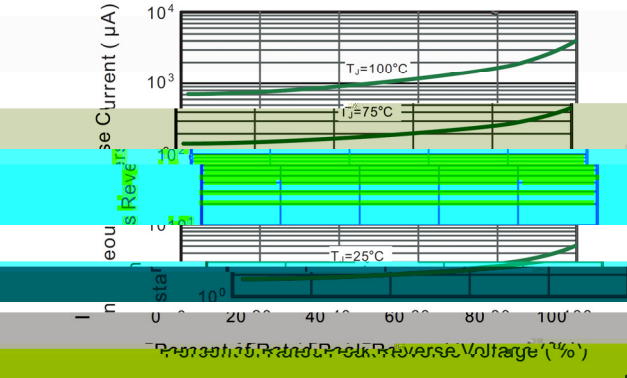

Fig.3 Typical Forward Characteristic

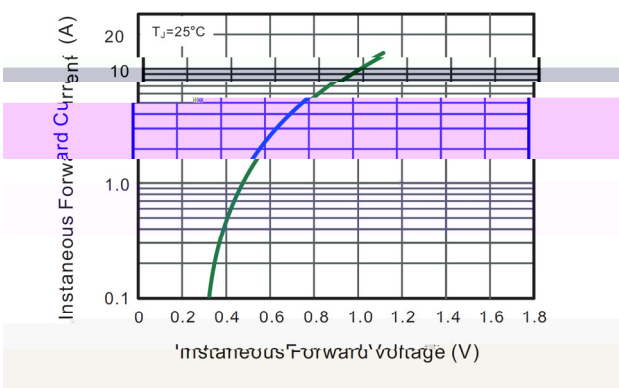

Fig.4 Typical Junction Capacitance

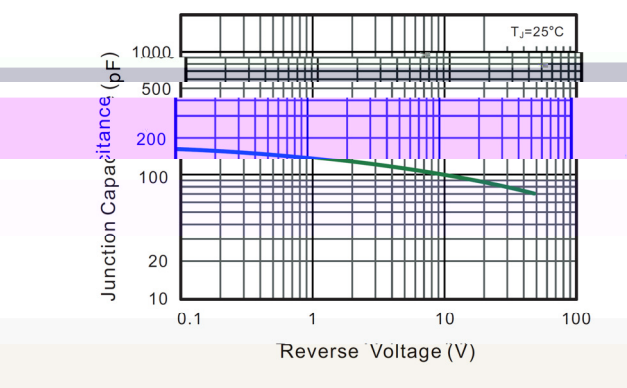

Fig.5 Maximum Non-Repetitive Peak Forward Surge Current

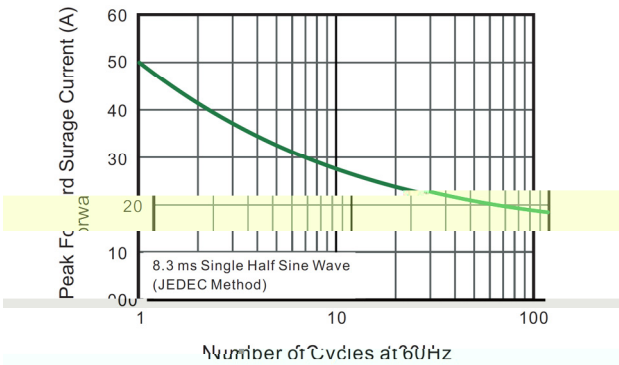
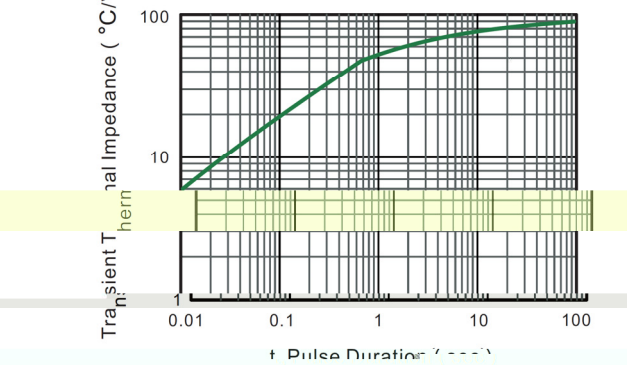
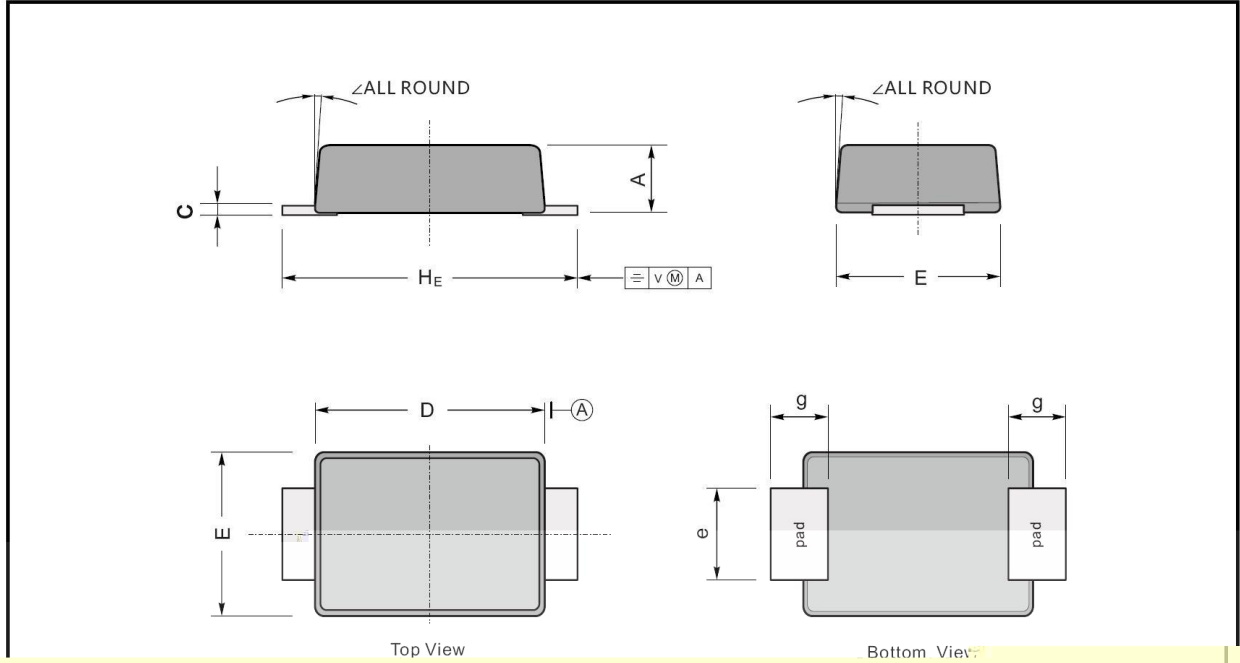

Fig.6 Typical Transient Thermal Impedance



/ Package Dimensions

SMAF



| UNIT | | A | C | D | E | e | g | H _E | \angle |
|------|-----|-----|------|-----|-----|-----|-----|----------------|----------|
| mm | max | 1.2 | 0.20 | 3.7 | 2.7 | 1.6 | 1.2 | 4.9 | 7° |
| | min | 0.9 | 0.12 | 3.3 | 2.4 | 1.3 | 0.8 | 4.4 | |
| mil | max | 47 | 7.9 | 146 | 106 | 63 | 47 | 193 | |
| | min | 35 | 4.7 | 130 | 94 | 51 | 31 | 173 | |

/ Marking Instructions



Note:

Product Type Code

Lot No. Code, code change with Lot No

() / Temperature Profile for IR Reflow Soldering(Pb-Free)

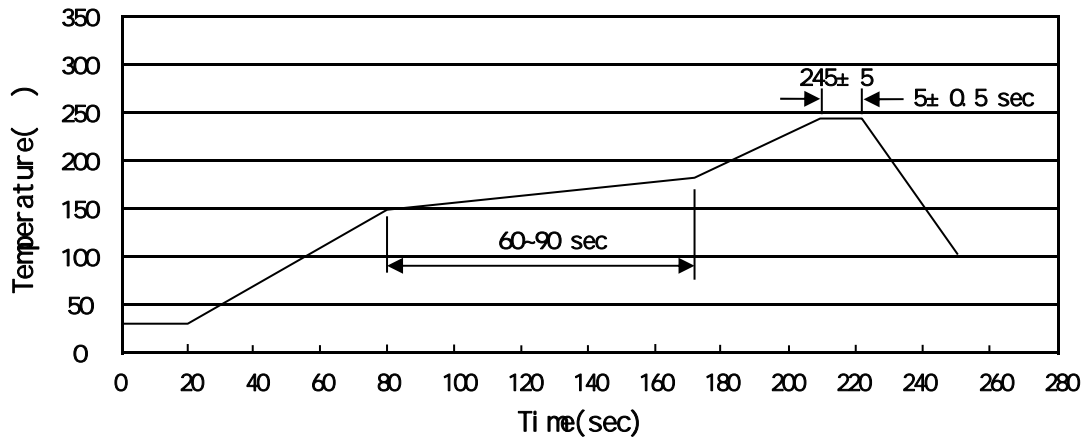

Note:

- 1 150 180 60 90sec; 1.Preheating:150~180 , Time:60~90sec.
- 2 245 5 5 0.5sec; 2.Peak Temp.:245 5 , Duration:5 0.5sec.
- 3 2 10 /sec. 3. Cooling Speed: 2~10 /sec.

/ Resistance to Soldering Heat Test Conditions

260 5 10 1 sec. Temp.:260 5 Time:10 1 sec

/ Packaging SPEC.

/ REEL

| Package Type | Units | | | | | Dimension (unit mm ³) | | |
|--------------|------------|-----------------|-----------------|-----------------------|-----------------|-----------------------------------|-------------|-------------|
| | Units/Reel | Reels/Inner Box | Units/Inner Box | Inner Boxes/Outer Box | Units/Outer Box | Reel | Inner Box | Outer Box |
| SMAF | 3,000 | 5 | 15,000 | 6 | 90,000 | 7" x12 | 185x180x105 | 390x385x205 |

/ Notices